

INSTALLATION, OPERATION AND MAINTENANCE INSTRUCTIONS

for the Installer and the User



HeatMaster

25 - 35 - 45 - 70 - 85 - 120 TC

Addendum - Declaration of Conformity i.a.w. Royal Decree (BE)

APPLICABILITY :

- 📄 664Y6900 - Rev E - HeatMaster 25-35-45-70-85-120 TC
- 📄 664Y7000 - Rev B - HeatMaster 25C



1/3

DÉCLARATION DE CONFORMITÉ A.R. 17/7/2009 - BE
(en accord avec la norme ISO/IEC 17050-1)

Nom et adresse du fabricant : **ACV International SA / NV**
Oude Vijverweg, 6
B-1653 Dworp
Belgique

Nom et adresse du distributeur sur le marché Belge : **ACV Belgium SA / NV**
Oude Vijverweg, 6
B-1653 Dworp
Belgique

Nous déclarons sous notre seule responsabilité que l'appareil spécifié ci-après, mis sur le marché en Belgique est conforme au modèle type décrit dans la déclaration de conformité CE et est produit et distribué suivant les exigences de l'A.R. du 17 juillet 2009.

Description du produit : **Chaudière à condensation**

Modèle(s) : **HeatMaster 25 C V15**
HeatMaster 25 TC V15
HeatMaster 35 TC V15
HeatMaster 45 TC V15
HeatMaster 70 TC V15
HeatMaster 85 TC V15
HeatMaster 120 TC V15

Organisme de contrôle : **KIWA (0063)**

CE # : **0063CQ3618**

Mesurés sur les produits suivants

Modèle(s)	CO - 0% O ₂ (ppm)	NOx - 0% O ₂ (mg/kWh)
HeatMaster 25 C V15	27	26,3
HeatMaster 25 TC V15	27	24,6
HeatMaster 35 TC V15	48	29,5
HeatMaster 45 TC V15	63	33,2
HeatMaster 70 TC V15	34	33,1
HeatMaster 85 TC V15	51	29,3
HeatMaster 120 TC V15	58	31,1

Dworp, 21/11/2019

R&D Director
Céline Coupain



3/3

KONFORMITÄTSEKTLÄRUNG A.R. 17/7/2009 - BE
(In Übereinstimmung mit der Norm ISO/IEC 17050-1)

Name und Adresse des Herstellers: **ACV International SA / NV**
Oude Vijverweg, 6
B-1653 Dworp
Belgien

Name und Adresse des Händlers auf dem belgischen Markt: **ACV Belgium SA / NV**
Oude Vijverweg, 6
B-1653 Dworp
Belgien

Wir erklären in alleiniger Verantwortung, dass das im Folgenden genannte, auf den belgischen Markt gebrachte Gerät mit dem in der EG- Konformitätserklärung beschriebenen Baumuster übereinstimmt und gemäß den AR-Anforderungen vom 17. Juli 2009 hergestellt und vertrieben wird.

Produktbeschreibung: **Brennwertkessel**

Modellbeschreibung: **HeatMaster 25 C V15**
HeatMaster 25 TC V15
HeatMaster 35 TC V15
HeatMaster 45 TC V15
HeatMaster 70 TC V15
HeatMaster 85 TC V15
HeatMaster 120 TC V15

Prüfstelle: **KIWA (0063)**

CE # : **0063CQ3618**

Gemessene Produkte

Modell	CO - 0% O ₂ (ppm)	NOx - 0% O ₂ (mg/kWh)
HeatMaster 25 C V15	27	26,3
HeatMaster 25 TC V15	27	24,6
HeatMaster 35 TC V15	48	29,5
HeatMaster 45 TC V15	63	33,2
HeatMaster 70 TC V15	34	33,1
HeatMaster 85 TC V15	51	29,3
HeatMaster 120 TC V15	58	31,1

Dworp, 21/11/2019

Leiter R & D
Céline Coupain



2/3

VERKLARING VAN OVEREENSTEMMING K.B. 17/7/2009 - BE
(In overeenstemming met de norm ISO/IEC 17050-1)

Naam en adres van de fabrikant : **ACV International SA / NV**
Oude Vijverweg, 6
B-1653 Dworp
Belgium

Naam en het adres van de verdeler op de Belgische Markt : **ACV Belgium SA / NV**
Oude Vijverweg, 6
B-1653 Dworp
Belgium

Wij verklaren op eigen verantwoordelijkheid dat de apparatuur zoals hierna beschreven op de Belgische markt is gebracht, dat deze toestellen in overeenstemming zijn met het type model beschreven in de bijhorende CE conformiteitsverklaring en geproduceerd en gedistribueerd volgens de eisen opgenomen in het KB van juli 17, 2009.

Type product : **Condentliesketel**

Modellen : **HeatMaster 25 C V15**
HeatMaster 25 TC V15
HeatMaster 35 TC V15
HeatMaster 45 TC V15
HeatMaster 70 TC V15
HeatMaster 85 TC V15
HeatMaster 120 TC V15

Keuringsorganisme : **KIWA (0063)**

CE # : **0063CQ3618**

Gemeten op volgende producten

Modellen	CO - 0% O ₂ (ppm)	NOx - 0% O ₂ (mg/kWh)
HeatMaster 25 C V15	27	26,3
HeatMaster 25 TC V15	27	24,6
HeatMaster 35 TC V15	48	29,5
HeatMaster 45 TC V15	63	33,2
HeatMaster 70 TC V15	34	33,1
HeatMaster 85 TC V15	51	29,3
HeatMaster 120 TC V15	58	31,1

Dworp, 21/11/2019

Director R&D
Céline Coupain



EXCELLENCE
IN HOT WATER

Addendum - NOx

APPLICABILITY :

- 📄 664Y6900 - Rev E - HeatMaster 25-35-45-70-85-120 TC
- 📄 664Y7000 - Rev B - HeatMaster 25C
- 📄 664Y6700 - Rev D - Prestige 24-32 Solo/Excellence
- 📄 664Y6200 - Rev F - Prestige 42-50-75-100-120 Solo
- 📄 664Y7300 - Rev C - WaterMaster 25-35-45-70-85-120

NOx (Class 6 / Classe 6 / Klass 6 / Clase 6 / Klasse 6 / Klasa 6 / класс 6)*

		Weighted / Pondéré/Gewogen / Ponderado / Pesata / Gewichtet / Średnio /Средневзвеш.	
HeatMaster	25 TC	mg/kWh	24,6
	35 TC	mg/kWh	29,5
	45 TC	mg/kWh	33,2
	70 TC	mg/kWh	33,1
	85 TC	mg/kWh	29,3
	120 TC	mg/kWh	31,1
HeatMaster	25 C	mg/kWh	26,3
Prestige	24 Solo/Excellence	mg/kWh	30,4
	32 Solo/Excellence	mg/kWh	35,6
	42 Solo	mg/kWh	28,8
	50 Solo	mg/kWh	35,1
	75 Solo	mg/kWh	43,2
	100 Solo	mg/kWh	34,2
	120 Solo	mg/kWh	39,6

* i.a.w. EN15502-1+A1:2015

NOx

		Weighted / Pondéré/Gewogen / Ponderado / Pesata / Gewichtet / Średnio /Средневзвеш.	
WaterMaster	25	mg/kWh	21,5
	35	mg/kWh	26,7
	45	mg/kWh	30,2
	70	mg/kWh	30,3
	85	mg/kWh	27,0
	120	mg/kWh	28,9

GENERAL RECOMMENDATIONS.....	3
Safety Instructions	3
USER'S GUIDE.....	4
Meaning of Symbols	4
Boiler Marking.....	5
Control Panel and Display	6
Stand-by Screen.....	7
Lockout Screen	7
Status Messages	7
What to Check on a Regular Basis	8
In case of Problem.....	8
Boiler Setup Guide	8
APPLIANCE DESCRIPTION.....	15
Models - HeatMaster® 25 - 35 - 45 - 70 - 85 - 120 TC.....	15
Configuration in a system.....	15
HeatMaster® 25 - 35 - 45 TC overview	15
HeatMaster® 70 - 85 - 120 TC overview.....	16
Connections - at the back.....	17
TECHNICAL CHARACTERISTICS.....	18
Dimensions	18
Clearance	19
gas categories (All models).....	19
Combustion characteristics.....	20
General Recommendations for Chimney Connection.....	21
Chimney connection characteristics.....	22
Calculation of the flue pipe length	23
Cascade : calculation of the maximum length of flue pipes	24
Electrical Characteristics HeatMaster® 25-35-45 TC	28
Electrical Characteristics HeatMaster® 70-85 TC	30
Electrical Characteristics HeatMaster® 120 TC.....	32
Hydraulic Characteristics	34
Hydraulic Pressure Drop Curve of the Boilers	34
DHW performance	34
Maximum Operating Conditions.....	34
Recommendations for the Prevention of Corrosion and Scaling in Heating Systems.....	35
G3 Requirements and Guidance - UK Only.....	36
INSTALLATION	38
Safety Instructions for the Installation	38
Package contents.....	39
Tools Required for the Installation.....	39

Boiler preparation.....	39
Recommendations for Hydraulic Connections.....	40
Recommendations for DHW Connections.....	40
DHW connection.....	40
Heating Connection	41
Removal and Installation of the Front and Top Panels.....	42
Recommendations for Gas Connection	42
Conversion to Propane	43
CONFIGURATION AND SYSTEM SET-UP	44
Basic Configuration - HeatMaster 25 TC V15: High Temperature Heating Circuit Controlled by Room Thermostat and Optional Outdoor Sensor.....	44
Cascade Configuration, Controlled by EBV Controller	45
STARTING UP	46
Safety Instructions for Starting up	46
Tools Required for Starting up.....	46
Checks before Starting up.....	46
Filling the system	46
Starting up the Boiler	47
Checking and Adjusting the Burner	47
MAINTENANCE.....	48
Safety Instructions for the Boiler Maintenance	48
Tools Required for Maintenance	48
Boiler shut down for Maintenance.....	48
Periodic Boiler Maintenance Tasks.....	48
Draining the Boiler	49
Removal, Check and Installation of the Burner Electrode	49
Removal and Installation of the Burner	50
Torque Values	51
Cleaning the Exchanger	52
Restarting after Maintenance	52
LOCKING CODES	53
SERVICE LOG.....	56
DECLARATION OF CONFORMITY.....	57
ADDITIONAL ECODESIGN DATA.....	57
PRODUCT FICHE.....	58

GENERAL RECOMMENDATIONS

NOTE

This manual contains important information with respect to the installation, the starting up and the maintenance of the appliance.

This manual must be provided to the user, who will read it carefully and keep it in a safe place.

We accept no liability should any damage result from the failure to comply with the instructions contained in this technical manual.



Essential recommendations for safety

- It is prohibited to carry out any modifications to the appliance without the manufacturer's prior and written agreement.
- The product must be installed by a qualified engineer, in accordance with applicable local standards and regulations.
- The installation must comply with the instructions contained in this manual and with the standards and regulations applicable to heating systems.
- Failure to comply with the instructions in this manual could result in personal injury or a risk of environmental pollution.
- The manufacturer declines all liability for any damage caused as a result of incorrect installation or in the event of the use of appliances or accessories that are not specified by the manufacturer.



Essential recommendations for the correct operation of the appliance

- In order to ensure that the appliance operates correctly, it is essential to have it serviced by a certified installer or maintenance contractor every year.
- In case of anomaly, please call your service engineer.
- Faulty parts may only be replaced by genuine factory parts.



General remarks

- The availability of certain models as well as their accessories may vary according to markets.
- The manufacturer reserves the right to change the technical characteristics and features of its products without prior notice. Please check for an updated version of this manual in the documentation page on the website www.acv.com.
- In spite of the strict quality standards that ACV applies to its appliances during production, inspection and transport, faults may occur. Please immediately notify your approved installer of any faults.

GENERAL SAFETY INSTRUCTIONS FOR GAS APPLIANCES

If you smell gas:

- Immediately isolate the gas supply.
- Open windows and doors to ventilate the area.
- Do not use any electrical appliances and do not operate any switches.
- Immediately notify your gas supplier and/or your installer.

DO NOT STORE ANY FLAMMABLE OR CORROSIVE PRODUCTS, PAINT, SOLVENTS, SALTS, CHLORIDE PRODUCTS AND OTHER DETERGENT PRODUCTS NEAR THE APPLIANCE.

THIS APPLIANCE CAN BE USED BY CHILDREN AGED FROM 8 YEARS OLD AND ABOVE AND PERSONS WITH REDUCED PHYSICAL, SENSORY OR MENTAL CAPABILITIES OR LACK OF EXPERIENCE AND KNOWLEDGE, IF THEY HAVE BEEN GIVEN SUPERVISION OR INSTRUCTION CONCERNING THE USE OF THE APPLIANCE IN A SAFE WAY AND UNDERSTAND THE HAZARDS INVOLVED.

CLEANING AND USER MAINTENANCE SHALL NOT BE PERFORMED BY CHILDREN WITHOUT SUPERVISION.

CHILDREN SHALL NOT PLAY WITH THE APPLIANCE.











A BYPRODUCT OF ANY GAS FIRED APPLIANCE IS CARBON MONOXIDE. ACV RECOMMENDS THE INSTALLATION OF A MINIMUM OF TWO (2) HARD-WIRED CARBON MONOXIDE DETECTORS WITH AN ALARM AND BATTERY BACK-UP; ONE IN THE MECHANICAL ROOM WHERE THE BOILER IS LOCATED AND ANOTHER INSTALLED IN THE LIVING AREA OUTSIDE THE BEDROOM(S) FOR ALL INSTALLATIONS.









General remarks

- The end user is only allowed to carry out the basic set-up operations mentioned in "Boiler Setup Guide" on page 8, after he has received all relevant instructions from the installer. Any other set-up must be carried out by an approved installer.
- If the end user misuses the installer code to access installer-specific parameters and makes changes that cause a system failure, any warranty claim will be void.
- To get additional information on how to use the ACVMax interface, refer to the installer-specific settings and the detailed error codes, in the Installer's Handbook available at www.acv.com.

MEANING OF SYMBOLS

Symbols on the packaging	Meaning
	Fragile
	Keep dry
	Keep standing up
	Danger of tipping over
	Hand truck or pallet truck required for transport
Symbols on the appliance	Meaning
	Gas connection
	Condensate trap (ball syphon)
	Domestic Hot Water circuit
	Primary circuit
	Electricity
	Alarm

Symbols in the manual	Meaning
	Essential recommendation for safety (of persons and equipment)
	Essential recommendation for electrical safety (electrical hazard)
	Essential recommendation for the correct operation of the appliance or the system
	General remark
	Safety valve connected to the sewage system
	Connection to the sewage system

BOILER MARKING

Location: Back panel



The part number (Code) and serial number (N°) of the appliance are indicated on its rating plate and must be provided to ACV in case of warranty claim. Failure to do so will make the claim void.

Made in BELGIUM
ACV INTERNATIONAL
Oude Vijverweg 6
1653 Dworp
Belgium
international.info@acv.com

(21) 123456 (01) 0565201 (02) 2018

05E(S) - 2025 mbar	BE
02HSP - 2023750 mbar	AT
02HSP - 2050 mbar	CH, SK
02HSP - 203750 mbar	CZ, ES, GB, GR, HR, IE, IT, LT, PL, PT
02ELLSP - 2050 mbar	DE
02HSP - 2030 mbar	FI, RO, SI
02ERP - 20253050 mbar	FR
02HSP - 2030 mbar	LU
02EKSP - 20253050 mbar*	NL
02H - 20 mbar	LV, DK

N°: 18/123456
ANNO: 2018
CODE: 0565201
CL. NOx: 5
PERFORMANCE: ★★★★★
PIN: 0063CQ3618
MODEL: HeatMaster 25 TC V15

Adjusted - Réglé - Afgesteld G20 - 20 mbar
Type: B23-B23P-C13(x)-C33(x)-C43(x)-C53(x)-C63(x)-C83(x)-C93(x)

~ 230 V	PMS = 3 bar	PMW = 8,6 bar
50 Hz	T max = 87 °C	T max = 87 °C
101 W	100l	100l

G20	G25	G31	G25.3
Qn (H)	25	25	25
Ph (80-60°C)	24.3	24.3	24.3
Q min (H)	4.7	4.7	4.7
P min (80-60°C)	4.6	4.6	4.6

* 02EK (WOBBE)(43.46 - 45.3 MJ/h)(°C)/SP
Condensate ketel - Chaudière à condensation - Condensing boiler - Brennerkessel - Caldaia a condensazione - Caldera de condensación

HeatMaster 25 TC

Made in BELGIUM
ACV INTERNATIONAL
Oude Vijverweg 6
1653 Dworp
Belgium
international.info@acv.com

(21) 123456 (01) 0565201 (02) 2018

05E(S) - 2025 mbar	BE
02HSP - 2023750 mbar	AT
02HSP - 2050 mbar	CH, SK
02HSP - 203750 mbar	CZ, ES, GB, GR, HR, IE, IT, LT, PL, PT
02ELLSP - 2050 mbar	DE
02HSP - 2030 mbar	FI, RO, SI
02ERP - 20253050 mbar	FR
02HSP - 2030 mbar	LU
02EKSP - 20253050 mbar*	NL
02H - 20 mbar	LV, DK

N°: 18/123456
ANNO: 2018
CODE: 0565201
CL. NOx: 5
PERFORMANCE: ★★★★★
PIN: 0063CQ3618
MODEL: HeatMaster 35 TC V15

Adjusted - Réglé - Afgesteld G20 - 20 mbar
Type: B23-B23P-C13(x)-C33(x)-C43(x)-C53(x)-C63(x)-C83(x)-C93(x)

~ 230 V	PMS = 3 bar	PMW = 8,6 bar
50 Hz	T max = 87 °C	T max = 87 °C
111 W	100l	100l

G20	G25	G31	G25.3
Qn (H)	35	35	35
Ph (80-60°C)	34.1	34.1	34.1
Q min (H)	7	7	7
P min (80-60°C)	6.8	6.8	6.8

* 02EK (WOBBE)(43.46 - 45.3 MJ/h)(°C)/SP
Condensate ketel - Chaudière à condensation - Condensing boiler - Brennerkessel - Caldaia a condensazione - Caldera de condensación

HeatMaster 35 TC

Made in BELGIUM
ACV INTERNATIONAL
Oude Vijverweg 6
1653 Dworp
Belgium
international.info@acv.com

(21) 123456 (01) 0565201 (02) 2018

05E(S) - 2025 mbar	BE
02HSP - 2023750 mbar	AT
02HSP - 2050 mbar	CH, SK
02HSP - 203750 mbar	CZ, ES, GB, GR, HR, IE, IT, LT, PL, PT
02ELLSP - 2050 mbar	DE
02HSP - 2030 mbar	FI, RO, SI
02ERP - 20253050 mbar	FR
02HSP - 2030 mbar	LU
02EKSP - 20253050 mbar*	NL
02H - 20 mbar	LV, DK

N°: 18/123456
ANNO: 2018
CODE: 0565201
CL. NOx: 5
PERFORMANCE: ★★★★★
PIN: 0063CQ3618
MODEL: HeatMaster 70 TC V15

Adjusted - Réglé - Afgesteld G20 - 20 mbar
Type: B23-B23P-C13(x)-C33(x)-C43(x)-C53(x)-C63(x)-C83(x)-C93(x)

~ 230 V	PMS = 3 bar	PMW = 8,6 bar
50 Hz	T max = 87 °C	T max = 87 °C
225 W	125l	190l

G20	G25	G31	G25.3
Qn (H)	69.9	69.9	69.9
Ph (80-60°C)	68	68	68
Q min (H)	20	20	20
P min (80-60°C)	19.5	19.5	19.5

* 02EK (WOBBE)(43.46 - 45.3 MJ/h)(°C)/SP
Condensate ketel - Chaudière à condensation - Condensing boiler - Brennerkessel - Caldaia a condensazione - Caldera de condensación

HeatMaster 70 TC

Made in BELGIUM
ACV INTERNATIONAL
Oude Vijverweg 6
1653 Dworp
Belgium
international.info@acv.com

(21) 123456 (01) 0565201 (02) 2018

05E(S) - 2025 mbar	BE
02HSP - 2023750 mbar	AT
02HSP - 2050 mbar	CH, SK
02HSP - 203750 mbar	CZ, ES, GB, GR, HR, IE, IT, LT, PL, PT
02ELLSP - 2050 mbar	DE
02HSP - 2030 mbar	FI, RO, SI
02ERP - 20253050 mbar	FR
02HSP - 2030 mbar	LU
02EKSP - 20253050 mbar*	NL
02H - 20 mbar	LV, DK

N°: 18/123456
ANNO: 2018
CODE: 0565201
CL. NOx: 5
PERFORMANCE: ★★★★★
PIN: 0063CQ3618
MODEL: HeatMaster 85 TC V15

Adjusted - Réglé - Afgesteld G20 - 20 mbar
Type: B23-B23P-C13(x)-C33(x)-C43(x)-C53(x)-C63(x)-C83(x)-C93(x)

~ 230 V	PMS = 3 bar	PMW = 8,6 bar
50 Hz	T max = 87 °C	T max = 87 °C
266 W	125l	190l

G20	G25	G31	G25.3
Qn (H)	85	85	85
Ph (80-60°C)	82.5	82.5	82.5
Q min (H)	21	17	23
P min (80-60°C)	20.5	6.8	22.3

* 02EK (WOBBE)(43.46 - 45.3 MJ/h)(°C)/SP
Condensate ketel - Chaudière à condensation - Condensing boiler - Brennerkessel - Caldaia a condensazione - Caldera de condensación

HeatMaster 85 TC

Made in BELGIUM
ACV INTERNATIONAL
Oude Vijverweg 6
1653 Dworp
Belgium
international.info@acv.com

(21) 123456 (01) 0565201 (02) 2018

05E(S) - 2025 mbar	BE
02HSP - 2023750 mbar	AT
02HSP - 2050 mbar	CH, SK
02HSP - 203750 mbar	CZ, ES, GB, GR, HR, IE, IT, LT, PL, PT
02ELLSP - 2050 mbar	DE
02HSP - 2030 mbar	FI, RO, SI
02ERP - 20253050 mbar	FR
02HSP - 2030 mbar	LU
02EKSP - 20253050 mbar*	NL
02H - 20 mbar	LV, DK

N°: 18/123456
ANNO: 2018
CODE: 0565201
CL. NOx: 5
PERFORMANCE: ★★★★★
PIN: 0063CQ3618
MODEL: HeatMaster 45 TC V15

Adjusted - Réglé - Afgesteld G20 - 20 mbar
Type: B23-B23P-C13(x)-C33(x)-C43(x)-C53(x)-C63(x)-C83(x)-C93(x)

~ 230 V	PMS = 3 bar	PMW = 8,6 bar
50 Hz	T max = 87 °C	T max = 87 °C
126 W	100l	100l

G20	G25	G31	G25.3
Qn (H)	45	45	45
Ph (80-60°C)	44.1	44.1	44.1
Q min (H)	9	9	9
P min (80-60°C)	8.8	8.8	8.8

* 02EK (WOBBE)(43.46 - 45.3 MJ/h)(°C)/SP
Condensate ketel - Chaudière à condensation - Condensing boiler - Brennerkessel - Caldaia a condensazione - Caldera de condensación

HeatMaster 45 TC

Made in BELGIUM
ACV INTERNATIONAL
Oude Vijverweg 6
1653 Dworp
Belgium
international.info@acv.com

(21) 123456 (01) 0565201 (02) 2018

05E(S) - 2025 mbar	BE
02HSP - 2023750 mbar	AT
02HSP - 2050 mbar	CH, SK
02HSP - 203750 mbar	CZ, ES, GB, GR, HR, IE, IT, LT, PL, PT
02ELLSP - 2050 mbar	DE
02HSP - 2030 mbar	FI, RO, SI
02ERP - 20253050 mbar	FR
02HSP - 2030 mbar	LU
02EKSP - 20253050 mbar*	NL
02H - 20 mbar	LV, DK

N°: 18/123456
ANNO: 2018
CODE: 0565201
CL. NOx: 5
PERFORMANCE: ★★★★★
PIN: 0063CQ3618
MODEL: HeatMaster 120 TC V15

Adjusted - Réglé - Afgesteld G20 - 20 mbar
Type: B23-B23P-C13(x)-C33(x)-C43(x)-C53(x)-C63(x)-C83(x)-C93(x)

~ 230 V	PMS = 3 bar	PMW = 8,6 bar
50 Hz	T max = 87 °C	T max = 87 °C
327 W	125l	190l

G20	G25	G31	G25.3
Qn (H)	115	115	115
Ph (80-60°C)	111.7	111.7	111.7
Q min (H)	23.2	23.2	23.2
P min (80-60°C)	22.5	22.5	22.5

* 02EK (WOBBE)(43.46 - 45.3 MJ/h)(°C)/SP
Condensate ketel - Chaudière à condensation - Condensing boiler - Brennerkessel - Caldaia a condensazione - Caldera de condensación

HeatMaster 120 TC

CONTROL PANEL AND DISPLAY

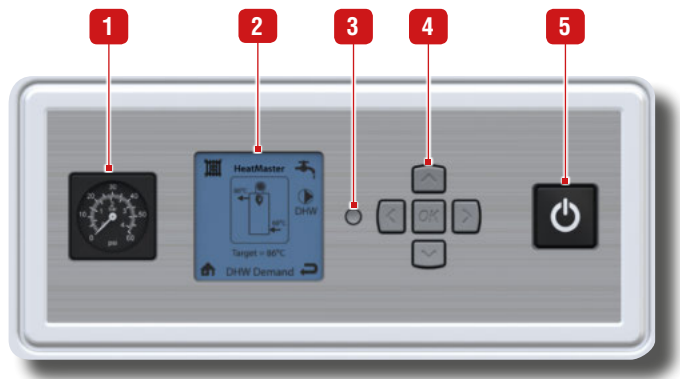

Panel Description

- 1. Pressure gauge** - Indicates the primary circuit pressure (min. 1 bar when cold).
- 2. ACVMAX LCD Display** - It is the setup interface of the boiler and indicates the parameter values, the error codes and the set-up status of the parameters. It displays a series of screens, each showing information and/or icons. The main icons are detailed on the right.
- 3. Installer button** - Allows the installer to access the menus of the ACVMAX controller to set up the system.
- 4. Arrow keys and OK key** - to browse through the screens of the ACVMAX controller, set up the boiler, increase and decrease the displayed values and validate the selections and access the Easy set-up screens. The OK key is also used to RESET the boiler after a locking (follow the instructions on the screen).
- 5. ON/OFF master switch of the boiler** - To turn the appliance ON and OFF.

Main settings of ACVMAX Display

- Screen backlight** - it will illuminate when any button is depressed, and remain illuminated for five minutes.
- Screen contrast** - it can be adjusted at the Home screen by pressing and holding the OK button, then pressing and holding the LEFT button along with the OK button. Press the UP and DOWN button to increase or decrease the contrast while holding the OK and LEFT buttons depressed. All buttons must be released and the procedure performed again to switch between increasing and decreasing contrast.

Main Icons of ACVMAX display

- Central Heating** - indicates information related to the CH circuit.
- DHW** - indicates information related to the Domestic Hot Water circuit.
- Home** - to go back to the main menu screen.
- Back** - to go back to the previous screen.
- Warm weather shutdown** - displays on the home screen when the outdoor temperature reaches the Warm Weather Shutdown preset temperature.
- Reset** - to reset the system to the factory settings.
- Parameters** - to access to the setup of controller parameters (language, units, etc.).
- Easy setup** - Indicates parameters that can be accessed through the EZ setup.
- CH/DHW operation** - To enable/disable the concerned circuit.
- Information** - To get information on the boiler.

Typical items appearing on the Home screen:

The boiler type is indicated at the top of the screen. The type and model are factory preset.

The boiler is represented in the centre of the Home Screen. Basic operating information such as supply and return temperatures are displayed as well as current burner status.

Radiator icon: indicates that a central heating call has been received. A small number 1 or 2 indicates which CH calls are active

A flame symbol is displayed when the unit is fired. The flame size changes to indicate the current firing rate.

Basic information. The user can toggle the items using the LEFT and RIGHT keys and view target, Supply, Return, Domestic, Outdoor and System temperatures.

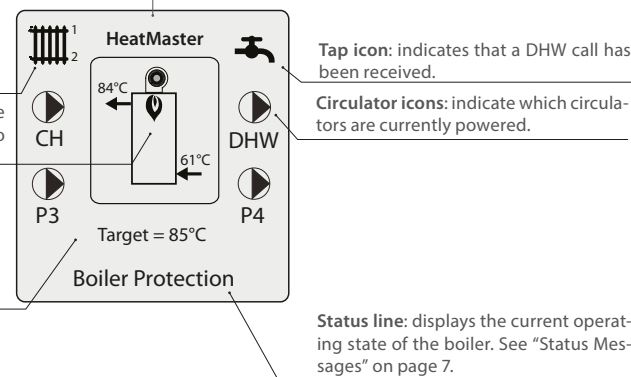

STAND-BY SCREEN

This screen is displayed at start-up. It indicates that the HeatMaster is ready to respond when a demand is received.

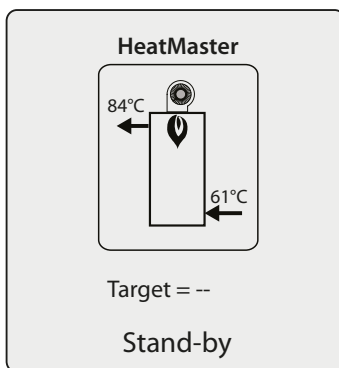

LOCKOUT SCREEN

If a problem occurs, the Lockout screen replaces the Home screen. The backlight also remains on as long as the problem is not solved. Pressing any arrow button will return to the Home screen.

Using the code located in the right bottom corner of the screen, troubleshoot the problem, either with the table located in paragraph "In case of Problem..." on page 8, or with the Lockout code table in the Installer's Handbook (for the installer only).

Low Water

Water pressure has fallen below 0.7 bar. Increase pressure to normal range.

If problem persists, call for service

E37

Lockout message. Refer to "In case of Problem..." on page 8 for more information.

Body text. The first sentence describes the lockout, the second sentence gives a possible cure, and the third tells how to reset the lockout.

Lockout reference code. Refer to "In case of Problem..." on page 8 for more information.

STATUS MESSAGES

Stand-by	Indicates that the HeatMaster is ready to respond when a demand is received.
CH Demand	A central heating call has been received.
DHW Demand	A domestic hot water call has been received.
CH / DHW Demand	Central heating and domestic hot water calls are being received simultaneously. Both calls are being satisfied simultaneously because domestic hot water priority has been disabled.
DHW Priority	Central heating and domestic hot water calls are being received simultaneously. Domestic hot water call is being satisfied first because it has priority over central heating calls.
Priority Timeout	Central heating and domestic hot water calls are being received simultaneously. The domestic hot water priority time limit has been exceeded. Priority will now switch back and forth between central heating and domestic hot water calls until one call is satisfied.
External Demand	An external modulation call has been received.
Manual Operation	The burner or circulators have manually been enabled in the Installer Menu.
CH Burner Delay	The burner will not fire until the call blocking time has elapsed.
DHW Burner Delay	The burner will not fire until the call blocking time has elapsed.
CH Setpoint Reached	The burner is not fired because the supply/system water temperature exceeds the setpoint. The central heating circulator continues to operate and the burner will fire again once the supply/system water temperature drops below the setpoint.
DHW Setpoint Reached	The burner is not fired because the supply/system water temperature exceeds the setpoint. The domestic circulator continues to operate and the burner will fire again once the supply/system water temperature drops below the setpoint.
CH Post Pump	The central heating circulator is running to remove heat from the HeatMaster at the completion of a call.
DHW Post Pump	The domestic hot water circulator is running to remove heat from the HeatMaster at the completion of a call.
Freeze Protection	The burner is fired because the freeze protection feature has been activated. Freeze protection will end once the supply/system water temperature is raised to 16°C.
Boiler Protection	The burner firing rate is being reduced because of an excessive difference between the boiler supply and return temperatures. The firing rate will begin increasing once the temperature difference is less than 25°C.
Lockout Description	The lockout which currently has the HeatMaster shut down is displayed

WHAT TO CHECK ON A REGULAR BASIS

Essential recommendations for the correct operation of the appliance

ACV recommends to check the system at least every 6 months as follows:

- Check that the system water pressure is at least 1 bar when cold. If the pressure drops below 0.7 bar, the built-in pressure sensor blocks the appliance until the pressure exceeds 1.2 bar.
- If it is required to top up the system to maintain the minimum recommended water pressure, always turn the appliance off and only add small amounts of water at a time. If a large amount of cold water is added in a hot boiler, the boiler can be damaged definitively.
- If the system needs to be refilled repeatedly with water, please contact your installer.
- Check that there is no water on the floor under the boiler. If there is, please call your installer.
- If a condensate neutralisation system is installed, check it and have it cleaned regularly.
- Check regularly that there is no error message (lockout) on the screen. A typical lockout screen is explained on the previous page. Refer also to the Troubleshooting table below or call your installer as required.

IN CASE OF PROBLEM...

Check the list of faults and corresponding codes below to get the solution(s). If no solution is provided here, please contact your installer who will determine the correct solution by referring to "Locking codes" on page 53.

Fault code	Problem	Possible Cause(s)	Solution
-	The appliance does not turn on when pressing the ON/OFF Master switch	No power supply	Check the power supply and that the appliance power plug is connected to the network.
E 01	Failed ignition	The burner failed to light after 5 ignition attempts	Check gas supply to the boiler.
E 13	Reset limit reached	Resets are limited to 5 every 15 minutes	Turn unit OFF and ON to resume normal operation.
E 34	Low voltage	Line voltage has fallen below an acceptable operating level	The boiler will automatically reset once line voltage returns to normal.
E 37	Low Water	Water pressure has fallen below an acceptable operating level (0.7 bar)	Refill the system to reach a normal range pressure. The boiler will automatically reset once water pressure returns to normal.
E 94	Internal Display Fault	Display memory error	Turn appliance off and on to resume normal operation.

BOILER SETUP GUIDE

The main parameters of the HeatMaster boilers can be set up using the EZ (easy) setup function of the ACVMax controller. The EZ setup function allows the user/installer to quickly setup the appliance for immediate operation according to the system configuration*.



General remarks

- To navigate on the screen, use the **UP**, **DOWN**, **LEFT** and **RIGHT** keys, then the **OK** key to validate a selection. A selection is marked by a black background under the selected icon/text.
- To increase/decrease values, use the **UP** and **DOWN** keys or the **LEFT** and **RIGHT** keys according to the situation.

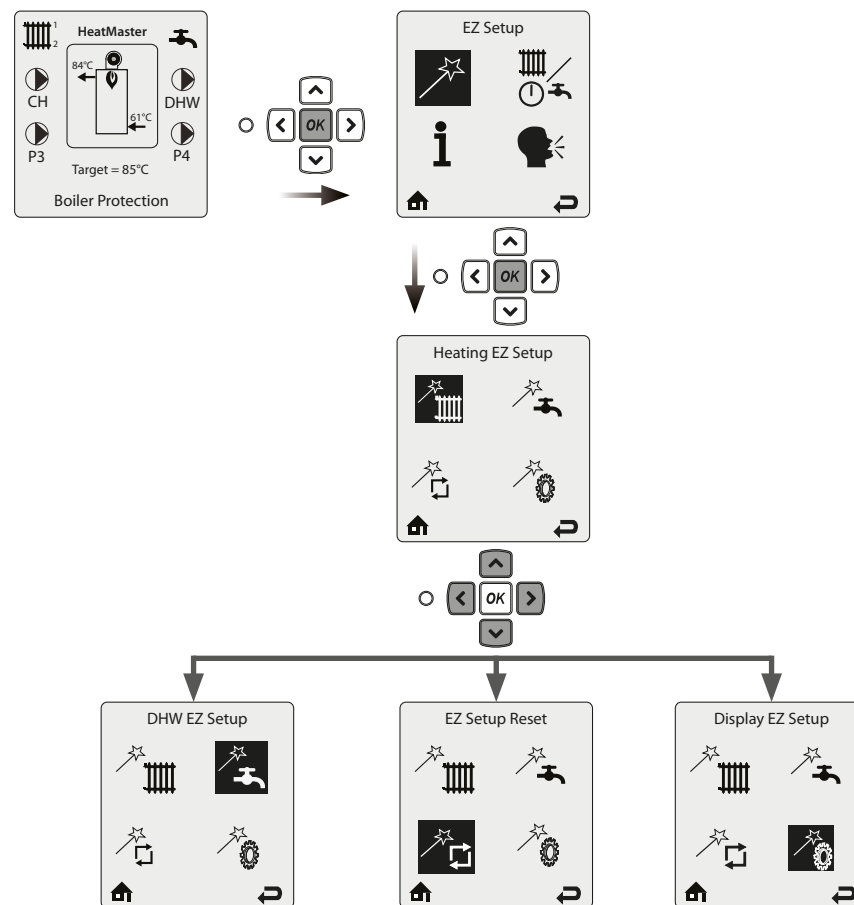

* In case of complex systems, the setup must be performed by an approved installer using the Installer's Handbook.



Heating Easy setup (no outdoor sensor connected)

- To navigate on the screen, use the **UP, DOWN, LEFT** and **RIGHT** keys, 
- Use the **OK** key to validate a selection.
- To increase/decrease values, use the **UP** and **DOWN** keys, or **LEFT** and **RIGHT**, according to the situation

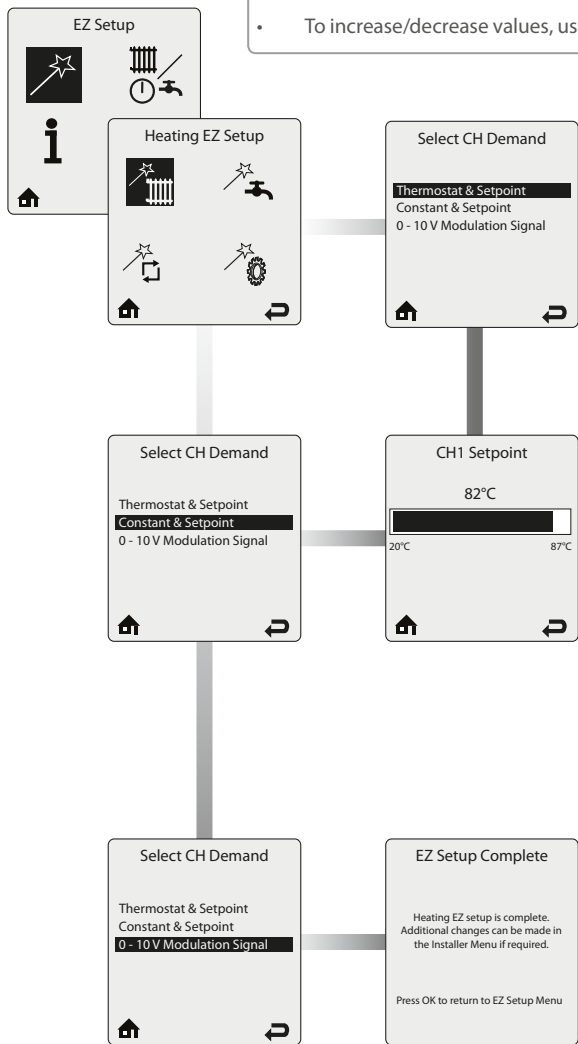

Select CH Demand prompts the installer to select how a CH Demand is generated. There are three Select CH Demand options, among which the installer must make a selection.

Thermostat & Setpoint - This option is only displayed when no outdoor temperature sensor is connected. A central heating call from a thermostat or zone panel will enable the HeatMaster and the setpoint will be fixed for central heating calls. When Thermostat & Setpoint is selected, the CH1 Setpoint screen appears.

Constant & Setpoint - The HeatMaster will maintain setpoint without an external CH call from a thermostat or zone panel. The setpoint will be fixed for CH calls. When Constant & Setpoint is selected, the CH1 Setpoint screen appears.

CH1 Setpoint prompts to enter the fixed setpoint for a CH1 heating call when a Setpoint option is chosen in Select CH Demand. Press on **LEFT** or **RIGHT** button to adjust the required temperature setpoint then press **OK** to store the setting. The **CH2 Setpoint** screen appears.

CH2 Setpoint prompts to enter the fixed setpoint for a CH2 heating call when a Setpoint option is chosen in Select CH Demand. Press on **LEFT** or **RIGHT** button to adjust the required temperature setpoint then press **OK** to store the setting and complete the Heating setting.

CH1 Default: 82°C.
CH2 Default: 60°C

0 - 10V Modulation Signal - This option allows the HeatMaster firing rate to be controlled by an external control system. Refer to Installer's Handbook, Volume 1, for more information.



Heating Easy Setup (outdoor sensor connected)

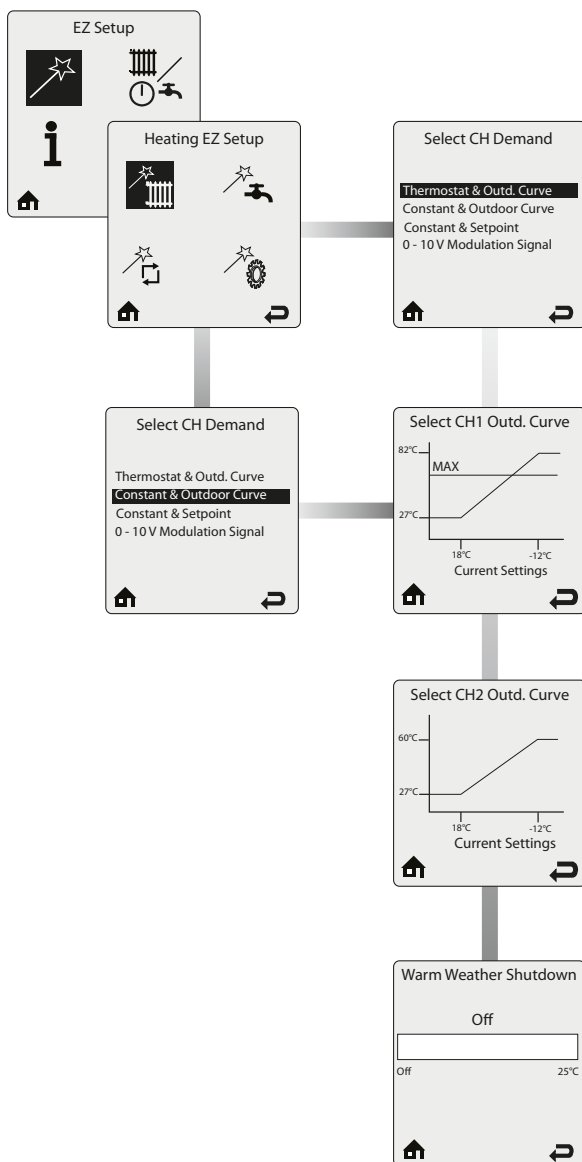

Select CH Demand prompts the installer to select how a CH Demand is generated. There are several Select CH Demand options, among which the installer must make a selection.

Thermostat & Outd. Curve – This option is only displayed when the outdoor temperature sensor is connected. A central heating call from a thermostat or zone panel will enable the boiler and the setpoint will vary with the outdoor temperature for central heating calls..

Constant & Outdoor Curve - This option is only displayed when the outdoor temperature sensor is connected. The HeatMaster will maintain the setpoint without an external call from a thermostat or zone panel. The setpoint will vary with the outdoor temperature for central heating calls.

Select CH1 Outd. Curve prompts to select an outdoor curve for a CH1 heating call when an Outdoor Reset option is chosen in Select CH Demand. Outdoor curve presets are available to cover most applications. The outdoor curve can also be adjusted to any desired settings in the Installer Menu (refer to Installer's Handbook).

Press on **UP** or **DOWN** button to select the outdoor reset curve appropriate for the type of heating system, then press **OK** to store the setting.

Default: Systems with a temperature between 27°C and 82 °C.

Select CH2 Outd. Curve prompts to select an outdoor curve for a CH2 heating call when an Outdoor Reset option is chosen in Select CH Demand. Outdoor curve presets are available to cover most applications. The outdoor curve can also be adjusted to any desired settings in the Installer Menu (refer to Installer's Handbook).

Press on **UP** or **DOWN** button to select the outdoor reset curve appropriate for the type of heating system, then press **OK** to store the setting.

Default: Systems with a temperature between 27°C and 60 °C

Warm Weather Shutdown allows to enter an optional outdoor temperature at which to disable the central heating function. The HeatMaster will continue to respond to a domestic hot water call or a 0- 10V Modulation Signal when the outdoor temperature exceeds the Warm Weather Shutdown Temperature setting.

Press the **LEFT** or **RIGHT** buttons to adjust the Warm Weather Shutdown Temperature then press the **OK** button to store the setting and complete the Heating setting.

The Warm Weather Shutdown icon (🌞) is displayed on the home screen when the outdoor temperature reaches the Warm Weather Shutdown preset temperature.

Default: OFF.

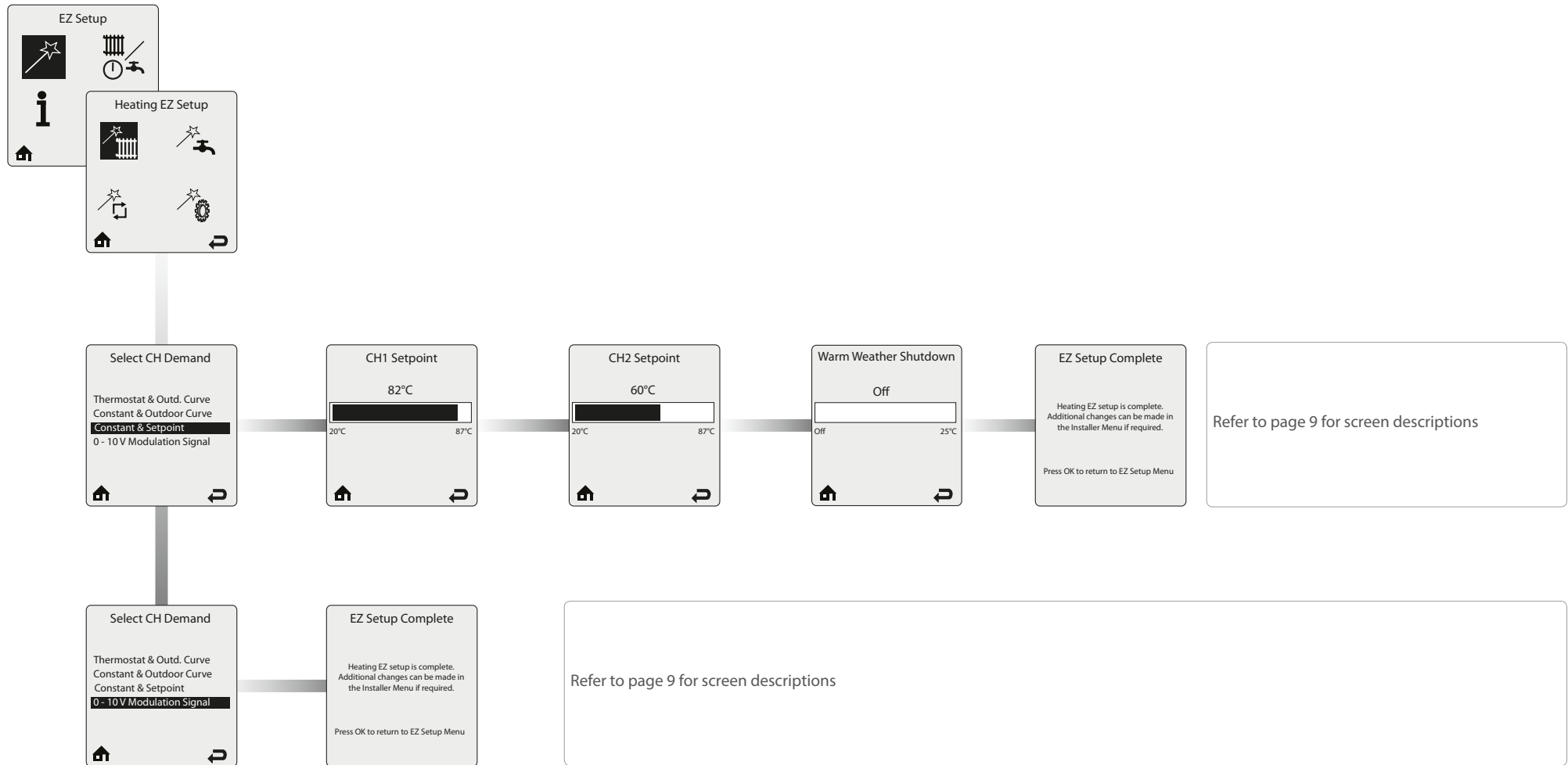



DHW Setup

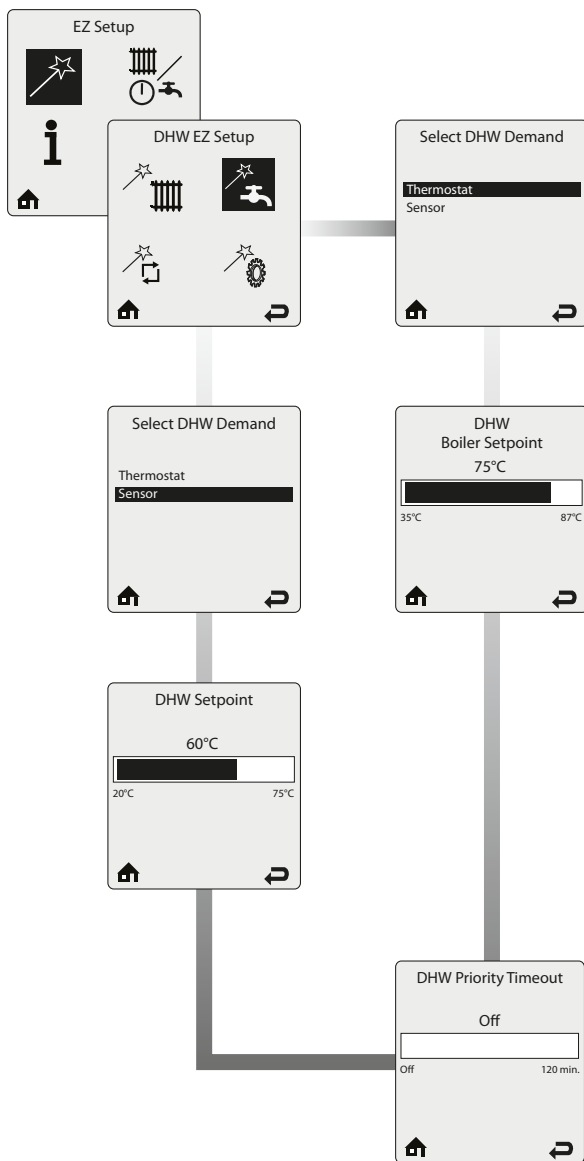

Select DHW Demand prompts the installer to select how a DHW Demand is generated. There are two Select DHW Demand options, among which the installer must make a selection.

When **Thermostat** is selected in Select DHW Demand, a domestic hot water call from an aquastat or dry contact switch will enable the HeatMaster with a fixed setpoint for a domestic hot water call.

When **Sensor** is selected in Select DHW Demand, it requires the use of an optional Indirect Water Heater Sensor. The HeatMaster monitors the DHW storage temperature and generates a DHW call whenever the temperature drops below the DHW storage setpoint by 3°C.

Default: Sensor

DHW Boiler Setpoint prompts to enter the fixed boiler setpoint temperature during a hot water call when the Thermostat option is selected.

Press on **LEFT** or **RIGHT** button to adjust the required temperature setpoint then press **OK** to store the setting.

Default: 75°C.

DHW Storage Setpoint prompts to enter the DHW storage setpoint temperature.

Press on **LEFT** or **RIGHT** button to adjust the required temperature setpoint then press **OK** to store the setting.

Default: 60°C.



The DHW Storage Setpoint will automatically be set 15°C higher than the DHW Setpoint setting

DHW Priority Timeout prompts to enter an optional time limit that a domestic hot water call has priority over central heating call.

Press on **LEFT** or **RIGHT** button to adjust the required timeout value, if required, then press **OK** to store the setting and complete the DHW setting.

Default: Off

 Easy Setup Reset

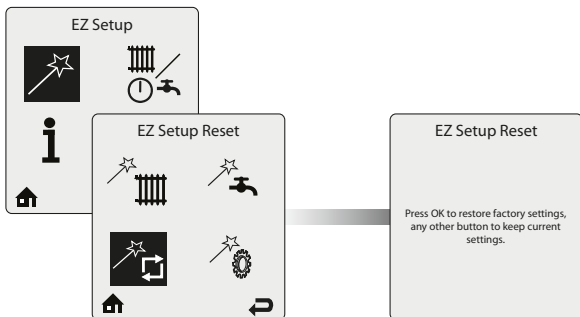

EZ Setup Reset allows to reset all EZ setup settings back to the original factory defaults.

Follow the on-screen instructions to reset all EZ setup settings.

 Display Easy Setup

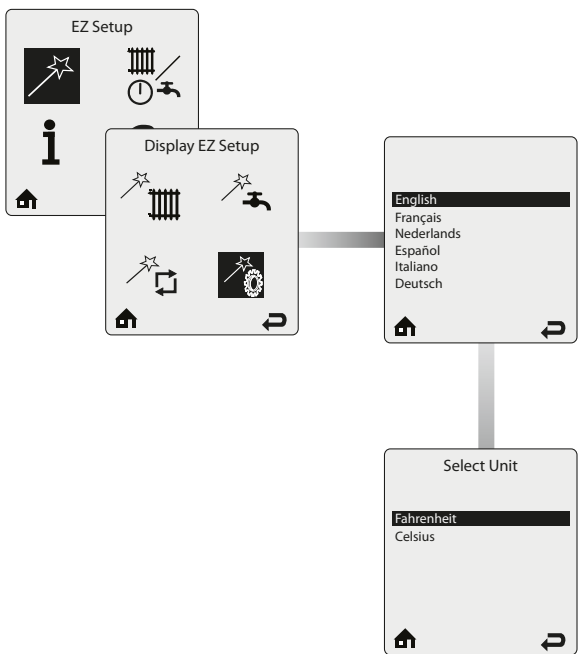

Display EZ Setup allows to select the interface language (Nine different languages: English, French, Dutch, Spanish, Italian, German, Czech, Polish and Russian).

Press on **UP** or **DOWN** button to select the required language then press **OK** to store the setting.

Display EZ Setup allows to select the interface temperature unit.

Press on **UP** or **DOWN** button to select the required unit then press **OK** to store the setting.

Starting from the Home screen :

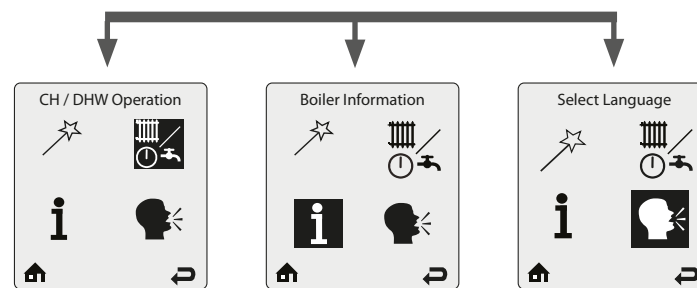
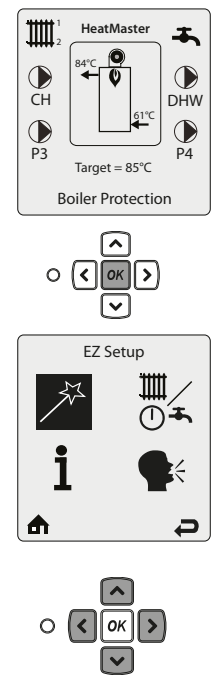

Selecting this icon and validating the selection with the OK key allows to access directly to the language selection page (see on the left)



CH/DHW Operation

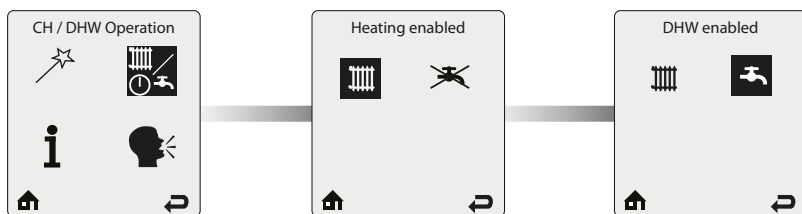

CH/DHW Operation provides a simple way to enable/disable either the CH or the DHW function of the HeatMaster.

Press on **LEFT** or **RIGHT** button to select the object (CH or DHW icon), then press **OK** to toggle between the enabled/disabled status. The status of the circuit is displayed at the top of the screen.

Using the arrow keys, select the **HOME** or **RETURN** icon at the bottom of the screen to go back either to the home page or to the previous screen respectively.

Default:  



Boiler Information

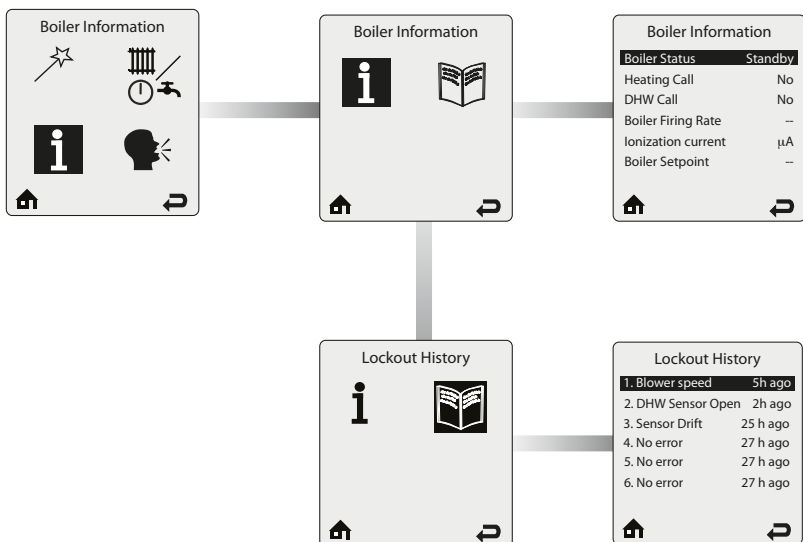

Boiler Information screen provides real time operating information of the HeatMaster. Each line contains an information item followed by its current value. Six lines are displayed on the screen at one time.

Press on **UP** or **DOWN** button to scroll through the items. For more information, refer to the Installer's Handbook of the HeatMaster boilers.

Lockout History records the last eight lockouts. Six lines are displayed on the Lockout History screen at one time. Each line contains a lockout description followed by how long ago the lockout occurred.

Press on **UP** or **DOWN** button to scroll through the items and on **OK** to select any of them and get more details through the **Lockout Details** screen. For more information, refer to the Installer's Handbook of the HeatMaster boilers.

APPLIANCE DESCRIPTION

MODELS - HEATMASTER® 25 - 35 - 45 - 70 - 85 - 120 TC

The HeatMaster® TC series is a range of condensing combination boilers. The boilers combine ACV's "Tank-in-Tank" concept with a double primary circuit to reach the high performance of a TOTAL CONDENSATION, double-circuit boiler.

All the HeatMaster® TC models are equipped with a high efficiency charging pump and with an ACV air/gas premix burner with low NOx emissions. During operation, the burner starts automatically as soon as the boiler temperature gets lower than the preset temperature and stops as soon as the preset temperature is reached.

The HeatMaster® TC series features a built-in frost protection mechanism: as soon as the flow temperature [NTC1 probe] drops below 7°C, the central heating pumps are activated. As soon as the flow temperature is at 5°C, the burner starts up until the flow temperature rises above 15°C. The pumps continue to run for around 10 minutes. The function can be enabled or disabled through the installer menu. When the frost protection is disabled, only the pumps operate.

An anti-freeze function is also available if an outdoor temperature sensor is connected, the pumps are activated when the outside temperature drops below the threshold defined through the Freeze protection function in the installer menu. In order to enable the HeatMaster boiler to protect the whole system against freezing, all the valves of the radiators and the convectors should be completely open.

CONFIGURATION IN A SYSTEM

The HeatMaster® TC boilers can be set up in different types of systems, either high or low temperature, or both, with or without external Domestic Hot Water tank. The HeatMaster® TC boilers can also be set up in a cascade system, using an external controller. Refer to "Configuration and system set-up" on page 44 for more information.

It is up to the installer to determine the best solution and reach the results the user is expecting.

One basic configuration is shown in this manual (see "Configuration and system set-up" on page 44), with the required accessories, required electrical connections and ACVMax setup using the EZ setup function.

Additional configurations requiring a more advanced setup are shown in the Installer's Handbook of the appliance. The setup of those systems must be made exclusively by the installer using the installer code.

For any other configuration that is not mentioned in either manuals, please contact your ACV representative.

- | | |
|--|--|
| 1. Concentric flue gas/air inlet box | 13. Electrical panel (with spare fuses at the back) |
| 2. Flue gas exhaust tube | 14. ACVMax Control panel |
| 3. Combustion chamber | 15. DHW tank dry well (Dip tube with temperature sensor) |
| 4. Stainless steel heat exchanger | 16. Automatic air vent |
| 5. Stainless steel "Tank-in-Tank" hot water production tank | 17. Gas pipe |
| 6. Primary circuit separation disc | 18. NTC1 sensor (CH supply) |
| 7. Indirect water pre-heater | 19. Gas valve |
| 8. Condensate recovery dish + NTC5 sensor (flue gas) (not shown) | 20. DHW safety valve / (T & P relief valve - UK only) |
| 9. Insulation | 21. Modulating air/gas premix burner with fan |
| 10. High efficiency circulator pump | 22. Air inlet |
| 11. NTC2 sensor (CH return) | |
| 12. Pressure sensor | |

HEATMASTER® 25 - 35 - 45 TC OVERVIEW

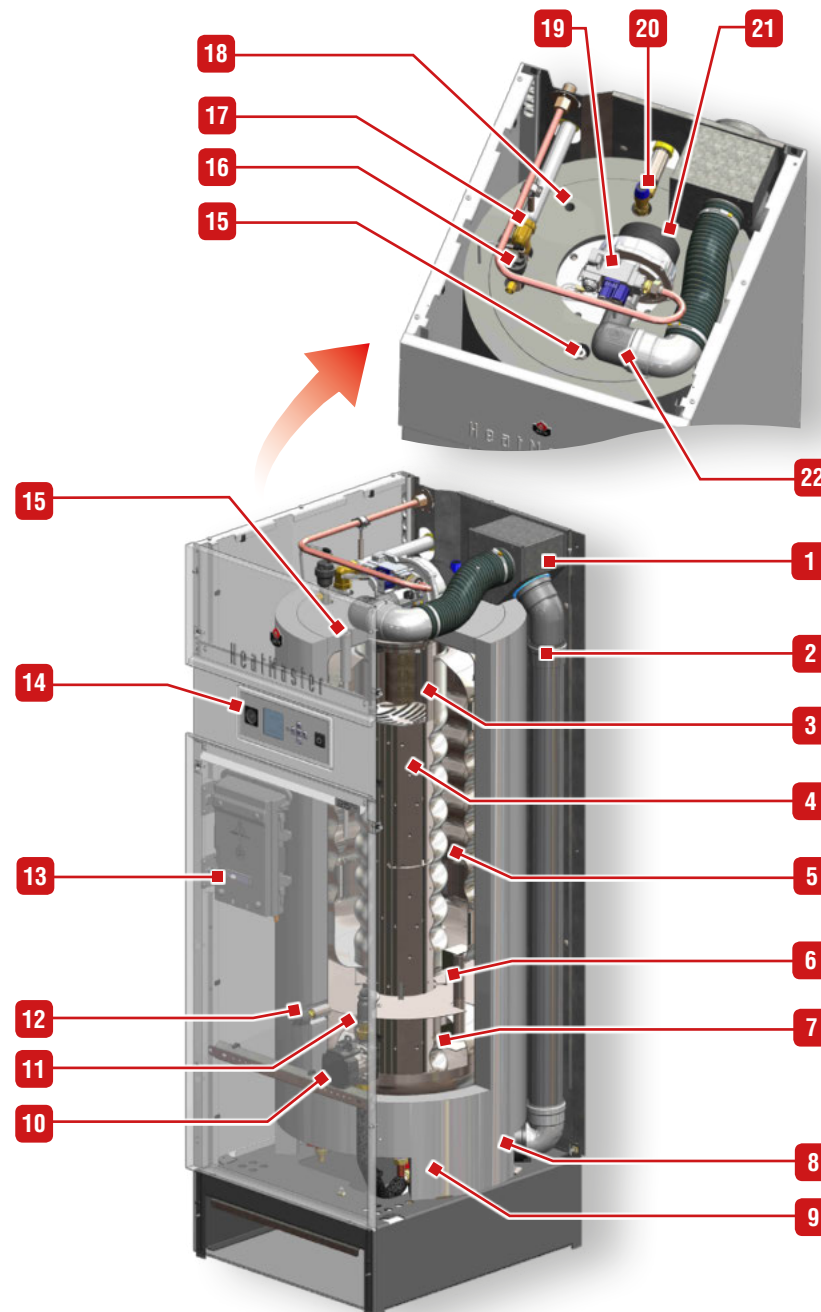

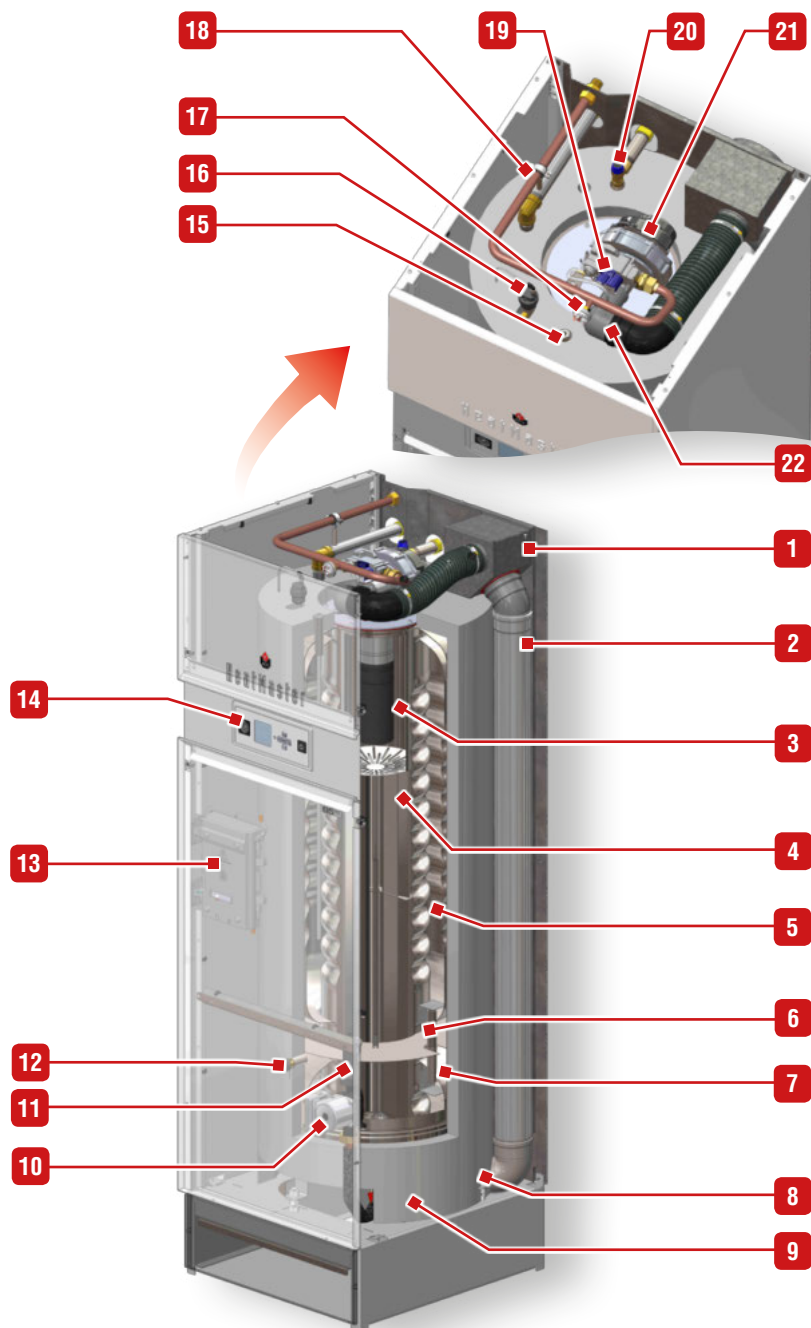

HeatMaster® 70-85 TC

HEATMASTER® 70 - 85 - 120 TC OVERVIEW

1. Concentric flue gas/air inlet box
2. Flue gas exhaust tube
3. Combustion chamber
4. Stainless steel heat exchanger
5. Stainless steel "Tank-in-Tank" hot water production tank (primary + DHW)
6. Primary circuit separation disc
7. Indirect water pre-heater
8. Condensate recovery dish + NTC5 sensor (flue gas) (not shown)
9. Insulation
10. High efficiency circulator pump
11. NTC2 sensor (CH return)
12. Pressure sensor
13. Electrical panel (with spare fuses at the back)
14. ACVMax Control panel
15. DHW tank dry well (Dip tube with temperature sensor)
16. Automatic air vent
17. Gas pressure switch
18. NTC1 sensor (CH supply)
19. Gas valve
20. DHW safety valve / (T & P relief valve - UK only)
21. Modulating air/gas premix burner with fan
22. Air inlet

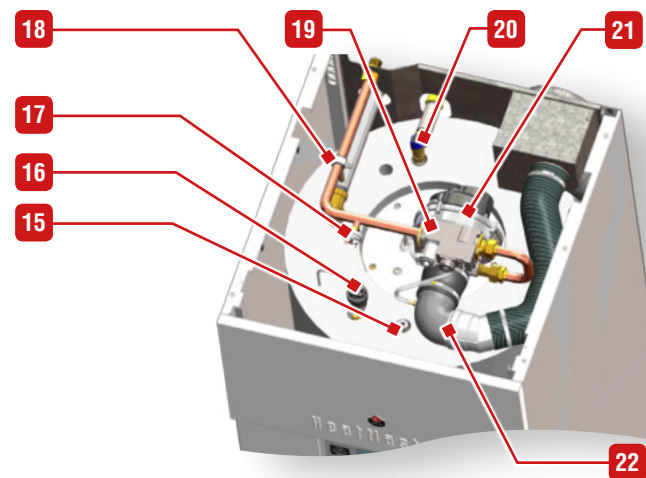





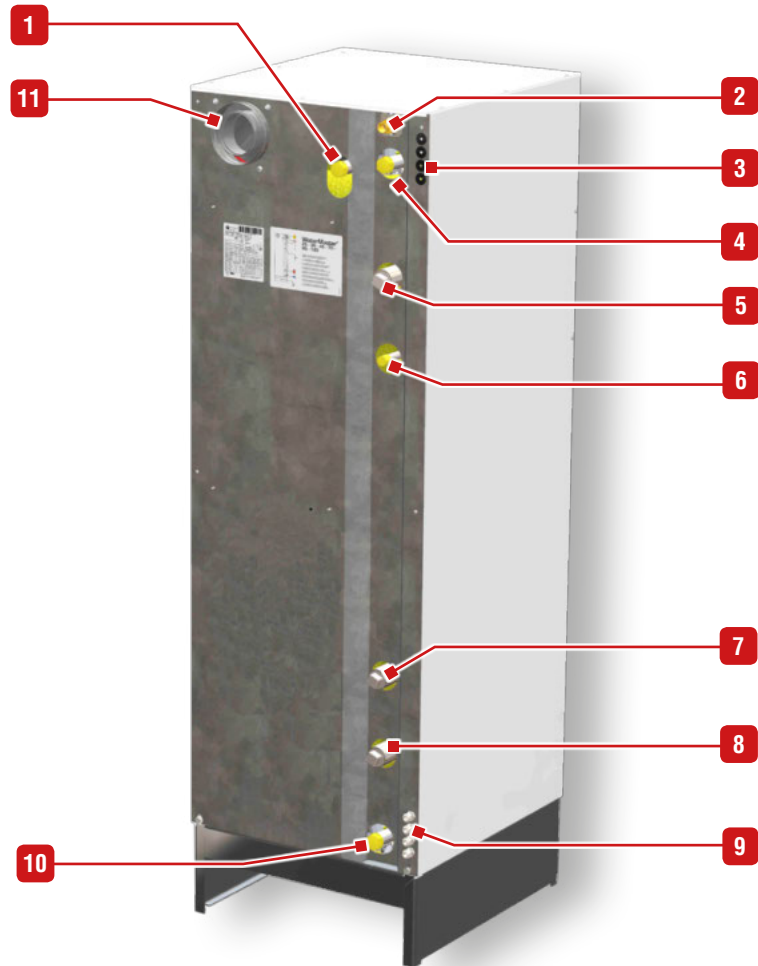

HeatMaster® 120 TC - Top view

CONNECTIONS - AT THE BACK



- | | |
|---|--|
| 1. Discharge for built-in DHW safety valve / (T & P relief valve - UK only) outlet to be connected to the sewage system | 7. Heating return connection [F] (HM 70 - 85 - 120 TC only) |
| 2. Gas connection [M] | 8. Heating return connection (HM 25 - 35 - 45 TC) / Heating return for low temp circuit (HM 70 - 85 - 120 TC only) |
| 3. Grommets for electrical wires (low voltage control) | 9. Grommets for electrical wires (230 V) |
| 4. Domestic Hot Water outlet [M] | 10. Domestic Hot Water inlet [M] |
| 5. Heating supply connection ([F]) | 11. Flue connection |
| 6. Connection for provided heating safety valve (to be installed). | |

DIMENSIONS

Boiler Dimensions		HM 25 - 35 - 45 TC	HM 70 - 85 TC	HM 120 TC
A	mm	1755	2170	2170
B	mm	600	690	690
C	mm	708	753	753
D	mm	80	100	100
E	mm	125	150	150
F	mm	145	155	155
G	mm	1670	2080	2080
H	mm	110	125	125
J ()	mm	1717	2126	2126
K ()	mm	1610	2030	2030
L ()	mm	1405	1750	1750
M (Safety valve)	mm	1295	1550	1550
N ()	mm	—	740	740
O ()	mm	446	—	—
O ( - Auxiliary connection)	mm	—	540	540
P ()	mm	273	311	311
Heating Connection [F]	"	1	1.1/2	1.1/2
DHW Connection [M]	"	1	1	1
Auxiliary connection [F]	"	—	1.1/2	1.1/2
Gas connection [M]	"	3/4	3/4	3/4
min. Ø of flue pipe	mm	80	100	100
Drained weight	Kg	177	298	299

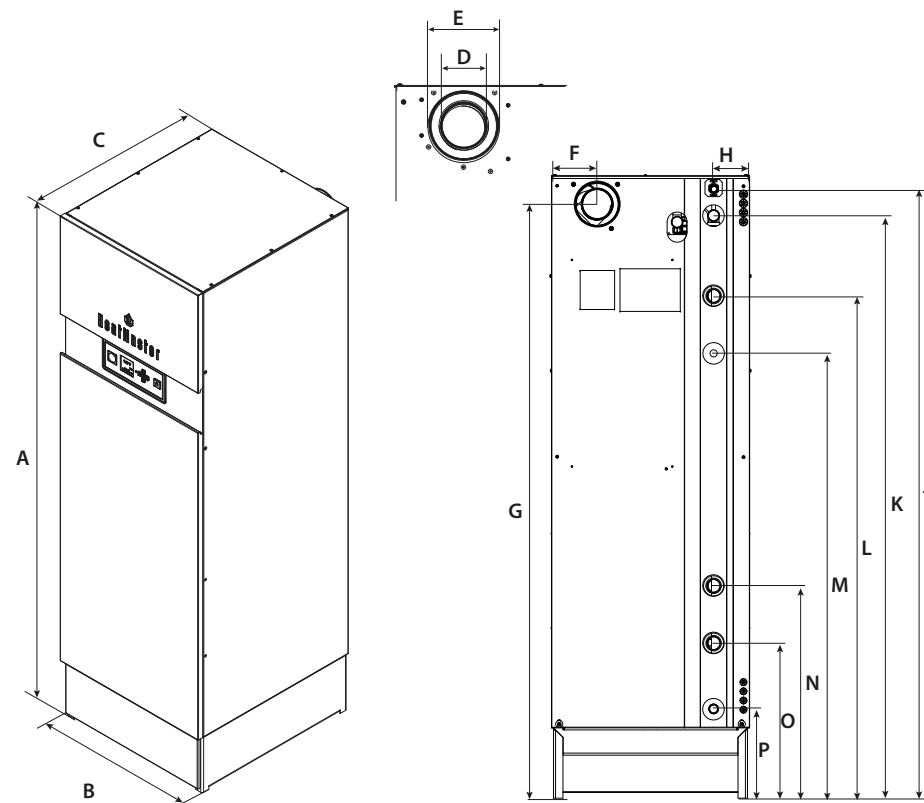

CLEARANCE

Boiler Clearance		HeatMaster® 25 - 35 - 45 - 70 - 85 - 120 TC
A (mm)	Recommended	400
	Minimum	300
B (mm)	Recommended	800
	Minimum	600
C (mm)	Recommended	400
	Minimum	250
D (mm)	Recommended	600
	Minimum	400

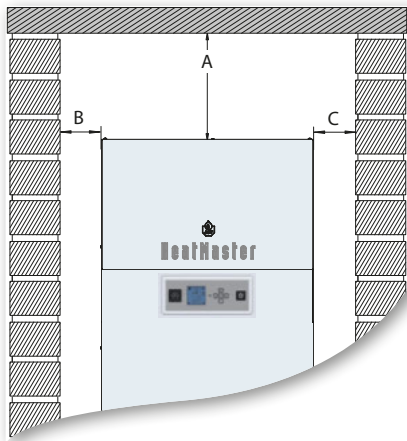

Front view

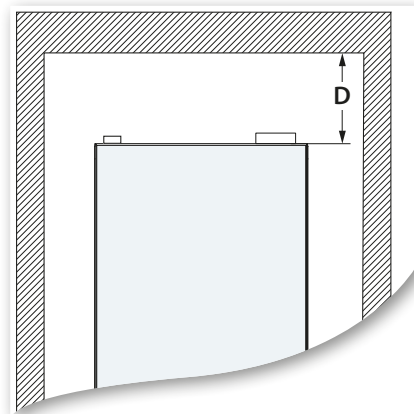

View from the top

GAS CATEGORIES (All models)

Gas type		G20	G25		G20 ⇄ G25		G31		
Pressure (mbar)		20	20	25	20 ⇄ 25		30	37	50
Country code	Category								
AT	112H3P	●							●
BE	12E(S)*				●				
	12E(R)**				●				
	13P						●		
CH	112H3P	●					●	●	
CZ	112H3P	●					●		
DE	112E3P	●						●	
	112ELL3P	●	●					●	
ES	112H3P	●					●		
FI	112H3P	●				●			
FR	112Er3P	●		●			●	●	
GB	112H3P	●					●		
GR	112H3P	●					●		
HR	112H3P	●					●		
IE	112H3P	●					●		
IT	112H3P	●					●		
LT	112H3P	●					●		
LU	112E3P	●				●			
LV	12H	●							
NL	112EK3P***			●			●		
	112L3P			●		●		●	
PL	112E3P	●					●		
PT	112H3P	●					●		
RO	112H3P	●				●			
SI	112H3P	●				●			
SK	112H3P	●					●	●	

* HM 25 / 35 / 45 / 70 TC
 ** HM 85 / 120 TC
 *** G25.3

COMBUSTION CHARACTERISTICS

Main Characteristics			HM 25 TC		HM 35 TC		HM 45 TC	
			G20/G25	G31	G20/G25	G31	G20/G25	G31
Input (PCI)	max	kW	25.0	25.0	34.9	34.9	45.6	45.6
	min	kW	5.0	5.0	7.0	7.0	9.0	9.0
Output at 100%	(80/60°C)	kW	24.3	24.3	34.1	34.1	44.1	44.1
	(50/30°C)	kW	26.0	26.0	36.4	36.4	46.8	46.8
Efficiency at 100%	(80/60°C)	%	97.3	97.3	97.9	97.9	98.0	98.0
	(50/30°C)	%	103.9	103.9	103.9	103.9	103.9	103.9
Efficiency at 30% load (EN677)		%	108.9	108.9	109.5	109.5	109.0	109.0
Combustion efficiency	at 100%	%	98.2	98.2	98.2	98.2	97.9	97.9
NOx (Class 5)	Max. output	mg/kWh	64	—	55	—	53	—
	Min. output	mg/kWh	12	—	12	—	21	—
	Weighted	mg/kWh	29	—	33	—	39	—
CO	Max. output	ppm	27	—	48	—	63	—
	Min. output	ppm	6	—	4	—	4	—
CO ₂	Max. output	%CO ₂	8.8	10.1	9.2/8.9	10.7	9.0	10.7
	Min. output	%CO ₂	8.3	9.3	8.8/8.4	10.2	8.4	10.1
Max gas flow rate G20/G25	20 mbar	m ³ /h	2.66	—	3.64	—	4.67	—
	25 mbar	m ³ /h	2.96	—	4.23	—	4.67	—
Max. gas flow rate G31	30/37/50 mbar	m ³ /h	—	0.98	—	1.4	—	1.77
		Kg/h	—	1.9	—	2.7	—	3.5
Temp of flue gases	Normal	°C	57.7	57.7	58.2	58.2	64.1	64.1
	Max.	°C	120	120	120	120	120	120
	Min.	°C	32.9	32.9	29.2	29.2	30.1	30.1
Average temp. of combustion products	DHW mode	°C	52.6	52.6	52.6	52.6	52.6	52.6
Mass flow rate* of flue gases	Normal	g/s	11.6	11.6	15.5	15.5	21.1	20.1
	Min. output	g/s	2.45	2.54	3.26	3.28	4.36	4.25
Standby loss	ΔT = 45 K	W	187	187	187	187	187	187
	ΔT = 30 K	W	113	113	113	113	113	113

Main Characteristics			HM 70 TC		HM 85 TC		HM 120 TC	
			G20/G25	G31	G20/G25	G31	G20/G25	G31
Input (PCI)	max.	kW	69.9	69.9	85.0	85.0	115.0	115.0
	min.	kW	21.5	21.5	21.0	21.0	25.0	25.0
Output at 100%	(80/60°C)	kW	68.0	68.0	82.9	82.9	111.7	111.7
	(50/30°C)	kW	74.0	74.0	89.9	89.9	121.7	121.7
Efficiency at 100%	(80/60°C)	%	97.3	97.3	97.0	97.0	97.0	97.0
	(50/30°C)	%	105.8	105.8	105.8	105.8	105.8	105.8
Efficiency at 30% load (EN677)		%	109.0	109.0	108.0	108.0	108.0	108.0
Combustion efficiency	at 100%	%	98.1	98.1	98.0	98.0	97.5	97.5
NOx (Class 5)	Max. output	mg/kWh	65	—	48	—	48	—
	Min. output	mg/kWh	23	—	26	—	23	—
	Weighted	mg/kWh	39	—	36	—	37	—
CO	Max. output	ppm	34	—	51	—	58	—
	Min. output	ppm	7	—	6	—	4	—
CO ₂	Max. output	%CO ₂	9.0	10.6	8.8/9.2	10.8	8.9/9.1	11.1
	Min. output	%CO ₂	8.4	10.0	8.3/8.4	10.0	8.4	10.4
Max gas flow rate G20/G25	20 mbar	m ³ /h	7.2	—	8.6	—	12.0	—
	25 mbar	m ³ /h	8.3	—	10.0	—	14.0	—
Max. gas flow rate G31	30/37/50 mbar	m ³ /h	—	2.77	—	3.37	—	4.68
		Kg/h	—	5.4	—	6.6	—	8.9
Temp of flue gases	Normal	°C	60	60	62	62	64.6	64.6
	Max.	°C	120	120	120	120	120	120
	Min.	°C	29.0	29.0	28.7	28.7	28.7	28.7
Average temp. of combustion products	DHW Mode	°C	51.0	51.0	51.0	51.0	51.0	51.0
Mass flow rate* of flue gases	Normal	g/s	31.6	31.6	30.8	37.8	50.8	49.8
	Min. output	g/s	10.19	9.98	10.19	9.98	12.14	11.5
Standby loss	ΔT = 45 K	W	342	342	342	342	342	342
	ΔT = 30 K	W	206	206	206	206	206	206

* Mass flow rate values were calculated for G20 and G31 with an air factor of 1.3.

GENERAL RECOMMENDATIONS FOR CHIMNEY CONNECTION

Essential recommendations for safety

- Do not install the boiler into a common flue piping with any other gas or oil appliances. This will cause flue gas spillage or appliance malfunction.
- Verify installed combustion air and flue piping are sealed gas tight and meet all provided instructions and applicable codes and standards.
- Failure to properly support the flue system can cause the flue system to fail, resulting in substantial property damage, serious injury, or death.
- A byproduct of any gas/oil fired appliance is carbon monoxide. Failure to install carbon monoxide detectors with alarms can result in serious injury, or death. Refer to applicable local regulations.

Essential recommendations for the correct operation of the appliance

- A condensation outlet connected to the sewer must be fitted close to the boiler to prevent the condensation products from the flue pipe from running into the boiler.
- Install a condensate neutralisation system if required by national and/or local regulations and have it cleaned regularly.
- Only use flue system components from the same manufacturer to connect this appliance and ensure that the pipe and connection diameters all match.
- Make sure to secure the flue piping to a solid structure.
- Exclusively use provided brackets to support the flue system.
- Install the horizontal flue pipes with a slight slope of 5 cm per meter (3°), so that the acid condensation water flows to a condensate recovery container and does not damage the heating body.

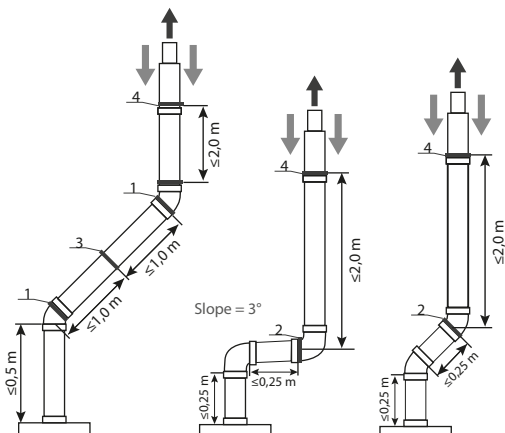

1. Each elbow and straight element will be secured at the sleeve.
2. In case the straight element before or after the first elbow is shorter than 25 cm, secure the straight element after the elbow using a bracket.
3. In case a straight (horizontal or sloped) element is longer than 1 m, support the element in its center using a clamp, making sure to allow free movement of the pipe.
4. Secure with a clamp every 2 meters in vertical piping/1 meter in horizontal/sloped piping, making sure to distribute the clamps evenly on the length of piping.

- If the appliance is provided with a condensate drain assembly, make sure to install the complete assembly on the boiler. If the assembly is incomplete, replace the entire assembly.
- Make sure that the condensate drain assembly is filled with water before starting up the boiler and check regularly the water level. Fill with water as necessary.
- It is mandatory to ventilate the boiler room. The high or low air vent opening dimensions depend on the boiler power and the boiler room size. Refer to the local regulations in force.
- If the combustion air inlet is located in an area likely to cause or contain contamination, or if products which could contaminate the air cannot be removed, the combustion air must be repiped and terminated at another location.
- Pool, laundry, common household, and hobby products often contain fluorine or chlorine compounds, which can form strong acids and corrode the internal components and flue system.
- In the case of parallel flue systems, make sure to maintain sufficient distance (at least 40 mm) between the boiler flue piping and combustible materials, and between the flue pipe and air inlet pipe if the latter is made of plastic material.
- Do not use screws to fasten together any flue pipe elements or any PP air inlet elements.
- Do not bond piping elements together using glue (e.g. silicone) or foam (e.g. PUR).



General remark

- For safety reasons and to make assembly easier, it is recommended to prefer the use of concentric flue pipes when possible.
- It is recommended to isolate the flue piping in damp rooms to prevent condensation water from forming on the piping and drip.
- When cutting the pipes to dimension, make sure to cut squarely and deburr the edges to prevent seals from being incorrect or damaged.
- To make piping assembly easier, exclusively use a mixture of water and soap (1% on the extremity of the pipe to be fit in).
- When fitting metal flue pipes, make sure to always fit the pipe into the sleeve to the end stop.
- When fitting plastic flue pipes, make sure to allow material expansion by leaving about 10 mm between the pipe end and the sleeve end stop.
- Make sure to install the piping without any strain.
- Make sure to install an inspection opening in the flue system.
- When connecting the flue pipes, make sure not to exceed the maximum length recommended for the product, otherwise the system power might decrease.
- ACV-approved components will be used for the chimney connection. Failure to do so will make any warranty claim void.
- For C63 connection type (not allowed in Belgium), make sure to use the correct piping material according to the resistance to temperature, pressure, chemical composition of flue, condensation and soot. A code (as explained in EN 1443), marked on the pipe, allows to determine if the material complies with the flue system requirements.

CHIMNEY CONNECTION CHARACTERISTICS

Main Characteristics		HM 25 TC	HM 35 TC	HM 45 TC	HM 70 TC	HM 85 TC	HM 120 TC						
Air/flue pipe Ø	concentric	mm	80/125	80/125	80/125	100/150	100/150						
	parallel	mm	80/80	80/80	80/80	100/100	100/100						
Max. allowed flue pipe pressure drop	Pa	95	130	130	110	160	170						
Max recommended length of concentric flue pipe (corresponding length in meters of straight pipes) * Ø 80/125		60	39	22	—	—	—						
Max recommended length of concentric flue pipe (corresponding length in meters of straight pipes) * Ø 100/150		130***	90***	53***	20	19	18						
Max recommended length of dual flow (corresponding length in meters of straight pipes) *	Rigid Ø 80	Flex. Ø 80	Rigid Ø 80	Flex. Ø 80	Rigid Ø 80	Flex. Ø 80	Rigid Ø 100	Flex. Ø 100	Rigid Ø 100	Flex. Ø 100	Rigid Ø 100	Flex. Ø 100	
	56	26	37	17	19	9	76	34	17	8	17	8	9
Available connection types		B23 - B23P - C13(x) - C33(x) - C43(x) - C53(x)** - C63(x) - C83(x), C93(x)											

* See next page to calculate the flue pipe length.

** A C53 connection of the HeatMaster TC boilers requires an optional accessory.

*** Not recommended - For more information, please contact your ACV representative.

 It is mandatory to ventilate the boiler room. The high or low air vent opening dimensions depend on the boiler power and the boiler room size. Refer to the local regulations in force.

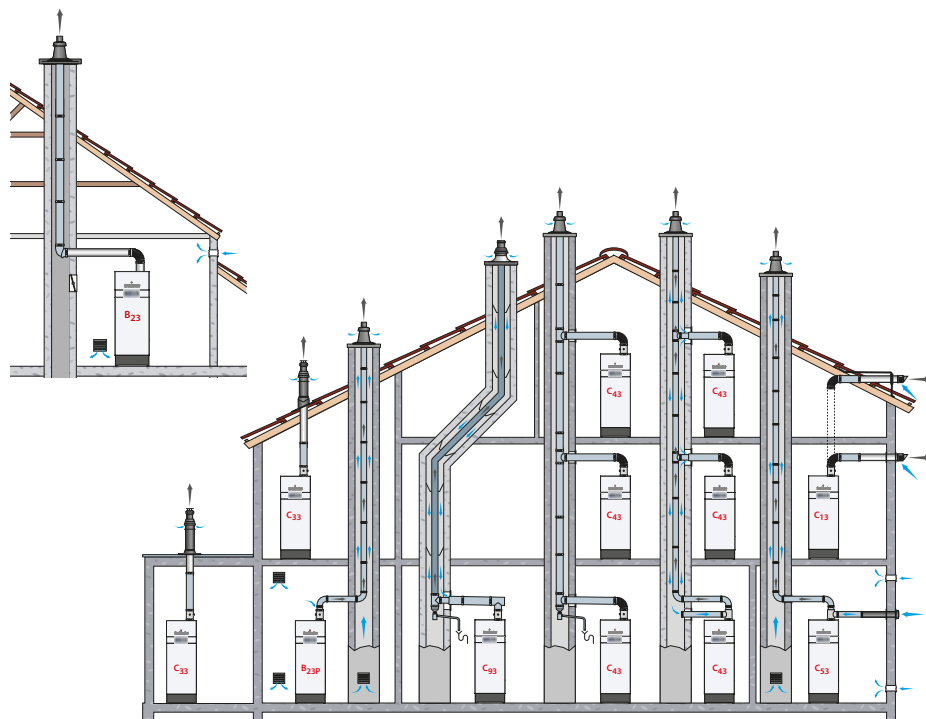

FLUE PIPE CONNECTION TYPES

 It is mandatory to use ACV flue systems to connect the appliance.

- B23P** : Connection to a combustion product exhaust system designed to operate with positive pressure.
- B23** : Connection to an exhaust duct that discharges the combustion products outside the room where it is installed, with the combustion air being drawn directly from the boiler room.
- C13(x)** : Connection using pipes fitted with a horizontal terminal that simultaneously takes in combustion air for the burner and discharges combustion products outside through openings that are either concentric or close enough together to be subjected to similar wind conditions, i.e. openings shall fit inside a square of 50 cm for boilers up to 70 kW and inside a square of 100 cm for boilers above 70 kW.
- C33(x)** : Connection using pipes fitted with a vertical terminal that simultaneously takes in fresh air for the burner and discharges combustion products outside through openings that are either concentric or close enough together to be subjected to similar wind conditions, i.e. openings shall fit inside a square of 50 cm for boilers up to 70 kW and inside a square of 100 cm for boilers above 70 kW.
- C43(x)** : Connection using two pipes to a collective duct system serving more than one appliance; this system of collective ducts features two pipes connected to a terminal unit that simultaneously takes in fresh air for the burner and discharges the combustion products outside through openings that are either concentric or close enough together to be subjected to similar wind conditions. C43(x) boilers are suitable for a connection to a natural draught chimney only.
- C53(x)** : Connection to separate ducts for supplying combustion air and discharging combustion products; these ducts may end in zones with different pressure levels, but are not allowed to be installed on opposite walls of the building.
- C63(x)** : Type C boiler meant to be connected to a system for supplying combustion air and discharging combustion products, that is approved and sold separately (**Prohibited in some countries (e.g. Belgium) - refer to local regulations and standards in force**). Terminals for the supply of combustion air and for the evacuation of combustion products are not allowed to be installed on opposite walls of the building. See also the following additional specifications:
- Maximum allowable draught is 200 Pa.
 - Maximum allowable pressure difference between combustion air inlet and flue gas outlet (including wind pressures) is as follows: 95 Pa (HM 25 TC), 130 Pa (HM 35- 45 TC), 110 Pa (HM 70 TC), 160 Pa (HM 85 TC) and 170 Pa (HM 120 TC).
 - Condensate flow is allowed into the appliance.
 - Maximum allowable recirculation rate of 10% under wind conditions.
- C83(x)** : Connection using a single or double duct system. The system is made of a normal exhaust flue duct that discharges the combustion products. The appliance is also connected through a second duct fitted with a terminal, that supplies the burner with fresh outdoor air. Please contact your ACV representative for the meters of flue pipes that can be used to connect the appliance(s).
- C93(x)** : Connection using an individual system whose combustion product exhaust duct is installed in an exhaust duct that is integral with the building. The appliance, the exhaust duct and the terminal units are certified as an inseparable assembly. Minimum usable diameter for the vertical duct supplying the combustion air is 100 mm.
-  The C93 configuration enables airtight operation in a pre-existing chimney. The combustion air crosses the space between the tubing and the pre-existing chimney. Make sure to clean the pre-existing chimney thoroughly prior to installation, especially if there is soot or tar residue. Make sure that there is a clearance area for the combustion air at least equivalent to the area that would have been provided by separate concentric ducts or air intake ducts.

CALCULATION OF THE FLUE PIPE LENGTH

i When connecting the flue pipes, make sure not to exceed the maximum flue pipe length, recommended for the product, otherwise the system pressure might decrease.

The flue pipe length can be calculated using the method shown below. Please refer to the tables below indicating the values in meters, applied to each of the connection components. Then compare the calculation result to the recommended maximum flue pipe length indicated in the table on previous page.

	Flue pipe length (L) (corresponding length in meters of straight pipe)			
	HM 25 - 35 - 45 TC		HM 25 - 35 - 45 - 70 - 85 - 120 TC	
	Concentric flue pipe Ø 80/125 mm	Parallel flue pipe Ø 80 mm	Concentric flue pipe Ø 100/150 mm	Parallel flue pipe Ø 100 mm
1 m straight pipe	1 m	1 m	1 m	1 m
90° elbow	2 m	2.3 m	2.2 m	3.7 m
45° elbow	1 m	1 m	1.3 m	2.3 m

i The equivalent length for pipes equipped with a measuring unit is equal to a 1 meter straight pipe

Example of verification of the flue pipe length (L) in a concentric flue pipe system for HeatMaster 35 TC (80/125):

The method is explained through an example.

Figure 1 : The assembly is comprised of:

1 pipe with a measurement unit + 3 x 90° elbows + 6 meters of straight pipes + 2 x 45° elbows

Method :

a) Using the above table, calculate the length in meters of the whole flue pipe assembly:

$$1 + (3 \times 2) + (6 \times 1) + (2 \times 1) = 15 \text{ m}$$

b) Compare the resulting value with the maximum length (39 m). This flue pipe length is within the recommended range.

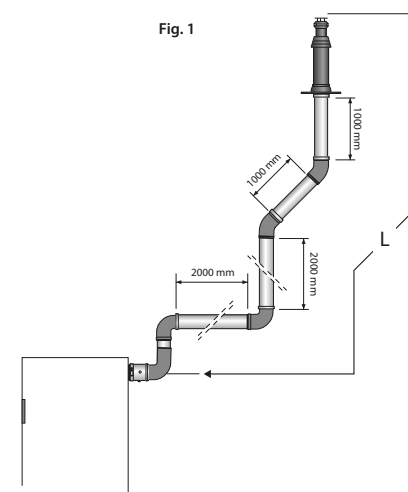
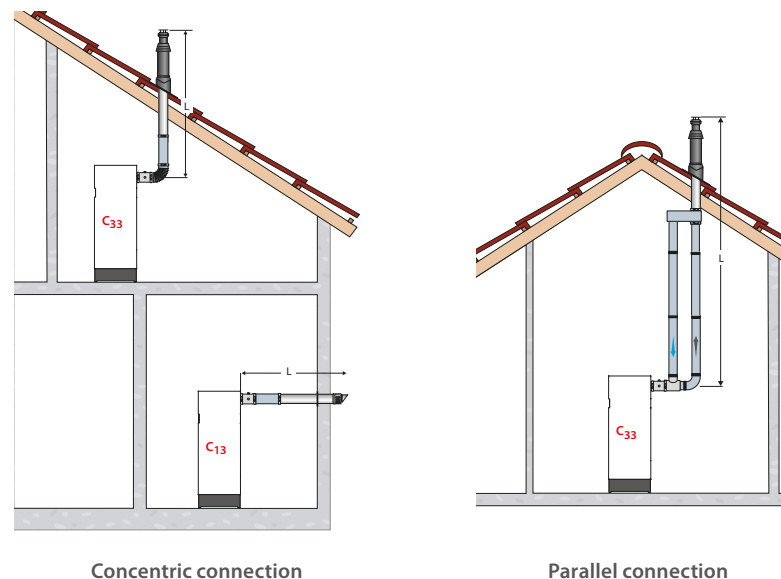

CASCADE : CALCULATION OF THE MAXIMUM LENGTH OF FLUE PIPES

HeatMaster 25 - 35 TC cascade in a C43 chimney connection configuration

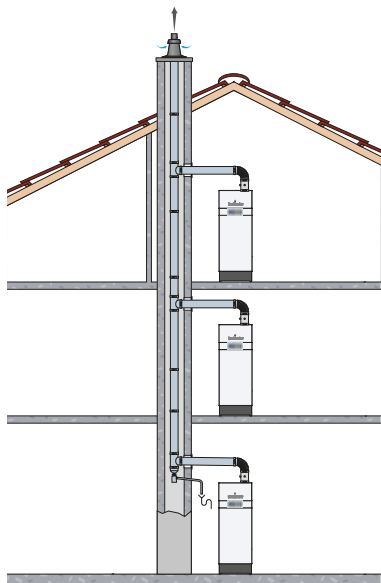

HeatMaster TC cascade in a B23 chimney connection configuration

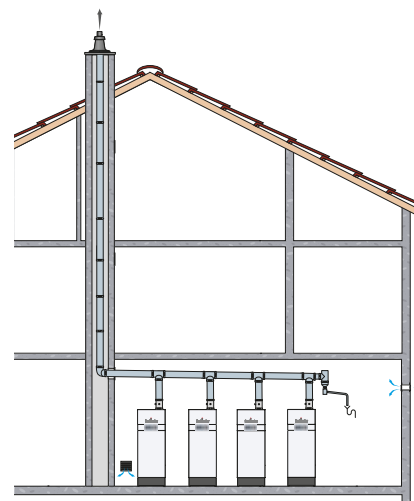

Elbow type	150	200
	L. Eq.	L. Eq.
45° [M]	1.7	3.8
90° [M]	4.0	5.8



Make sure to install an external non-return valve on the flue connection. Please contact your ACV representative for the correct accessory.

Qty	Appliance type*	Maximum length in M.		
		Dn 150	Dn 150/200**	Dn 200
2	HM 25 - 35 - 45 - 70 - 85 TC	30	30	30
	HM 120 TC	—	30	30
3	HM 25 - 35 - 45 TC	30	30	30
	HM 70 TC	25	30	30
	HM 85 TC	26	30	30
4	HM 120 TC	—	—	—
	HM 25 - 35 - 45 TC	30	30	30
	HM 70 TC	—	30	30
	HM 85 TC	—	30	30
5	HM 120 TC	—	—	—
	HM 25 - 35 - 45 TC	30	30	30
	HM 70 TC	—	30	30
	HM 85 TC	—	6	30
6	HM 120 TC	—	—	—
	HM 25 - 35 TC	30	30	30
	HM 45 TC	16	30	30
	HM 70 TC	—	—	30
	HM 85 TC	—	—	13
	HM 120 TC	—	—	—

* This table is for systems comprised of boilers with identical power. For any other configuration, please refer to your ACV representative.

**Dn 150/200 : Hor. = 150 mm, Vert.=200 mm

Boiler Models	Connection type	Material / Ø (mm)	Components *						
			Terminals	Pipes	Extensions	Bends	Measurement and condensate recovery	Accessories	Adapters
HeatMaster 25-35-45 TC	C93	PP Flex Ø 80	Set C93 Ø 80/125, (537D6287)	Flexible PP PP Ø 80, 25 m (537D6275)	—	—	—	<ul style="list-style-type: none"> • Connection sheath for Ø 80/125, Ø 80 (537D6266) • Connector Flex-Flex PP Ø 80 (537D6448) 	—
HeatMaster 25-35-45 TC	C13 C33	PP - Galva Ø 80/125	<ul style="list-style-type: none"> • Roof Terminal (537D6184) • Wall terminal kit (537D6185) • Wall terminal Kit (10800301) 	Lengths : <ul style="list-style-type: none"> • 250 mm (537D6186) • 500 mm (537D6187) • 1000 mm (537D6188) • 2000 mm (537D6516) 	Sliding extension , straight (+ 50 to 130 mm) (537D6189)	<ul style="list-style-type: none"> • 43° - 45° (537D6190) • 87° - 90° (537D6191) 	<ul style="list-style-type: none"> • Measuring Tube (537D6193) • Measuring T-piece with inspection (537D6229) 	<ul style="list-style-type: none"> • Weather Slate Steep (537D6182) • Bracket Ø 125 mm (537D6183) • Weather salte, flat roof (Ø 390 mm) (537D6194) 	<ul style="list-style-type: none"> • Expander SST/Alu Ø 80/125 mm - 2 x Ø 80 mm (537D6231) • Expander PP/ALU, Ø 60/100 mm - Ø 80/125 mm (537D6405)
HeatMaster 70-85-120 TC	C93	PP Flex Ø 100	Set C93 Ø 100/150, (537D6290)	Flexible PP Ø 100, 25 m (537D6271)	—	—	—	<ul style="list-style-type: none"> • Connection sheath Alu for Ø 100/150 (37D6267) • Adapter Flex-Flex PP Ø 100 (537D6451) 	—

* Designations and references (between brackets) are provided as information only. Please refer to the latest ACV Price list for more information and the correct references.

Boiler Models	Connection type	Material / Ø (mm)	Components *						
			Terminals	Pipes	Extensions	Bends	Measurement and condensate recovery	Accessories	Adapters
HeatMaster 70-85-120 TC	C13 C33	PP - Galva Ø 100/150	<ul style="list-style-type: none"> Roof Terminal (537D6300) Wall terminal kit (537D6301) 	Lengths : <ul style="list-style-type: none"> 250 mm (537D6302) 500 mm (537D6303) 1000 mm (537D6304) 2000 mm (537D6517) 	Sliding extension, straight (+ 50 to 130 mm) (537D6305)	<ul style="list-style-type: none"> 43° - 45° (537D6306) 87° - 90° (537D6307) 	<ul style="list-style-type: none"> Measuring Tube (537D6308) Measuring T-piece with inspection (537D6310) 	<ul style="list-style-type: none"> Weather Slate Steep 25°-45° (537D6209) Bracket Ø 150 mm (537D6210) Weather Slate, Flat roof (Ø 430 mm) (537D6208) 	Concentric to parallel Ø 100/150 mm - 2 x Ø 100 mm (537D6207)
HeatMaster 70-85-120 TC	B23P C53	SST Ø 150	<ul style="list-style-type: none"> Roof Terminal, flue Ø 150 (537D6211) Wall terminal kit, flue, Ø 150 (537D6212) Wall terminal kit, air, Ø 100 (537D6213) 	Lengths, flue, Ø 150 : <ul style="list-style-type: none"> 250 mm (537D6214) 500 mm (537D6215) 1000 mm (537D6216) Length, air, PVC Ø 100 : <ul style="list-style-type: none"> 500 mm (537D6217) 	Sliding extension, flue, Ø 150 (537D6218)	<ul style="list-style-type: none"> Flue, Ø 150, 45° (537D6219) Flue, Ø 150, 90° (537D6220) Air, Ø 100, 45° (537D6221) Air, Ø 100, 90° (537D6222) 	Element for measurement and recovery of condensates, flue, Ø 150 (537D6223)	<ul style="list-style-type: none"> Weather Slate Steep 25°-45° (537D6209) Bracket Ø 150 mm (537D6210) Weather Slate, Flat roof (Ø 430 mm) (537D6208) 	<ul style="list-style-type: none"> Expander Ø 100 - Ø 150 mm mandatory (537D6293) Concentric to parallel adapter Ø 100/150 mm - 2 x Ø 100 mm (537D6207) Adapter Ø 80 - Ø 100 mm, air (537D6172)

* Designations and references (between brackets) are provided as information only. Please refer to the latest ACV Price list for more information and the correct references.

Boiler Models	Connection type	Material / Ø (mm)	Components *						
			Terminals	Pipes	Extensions	Bends	Measurement and condensate recovery	Accessories	Adapters
HeatMaster 70-85-120 TC	C13 C33	SST - SST Ø 100/150	<ul style="list-style-type: none"> • Roof Terminal, (537D6197) • Wall terminal (537D6198) 	Lengths : <ul style="list-style-type: none"> • 250 mm (537D6199) • 500 mm (537D6200) • 1000 mm (537D6201) 	Sliding extension (280 to 395 mm) (537D6202)	<ul style="list-style-type: none"> • 43° - 45° (537D6203) • 87° - 90° (537D6204) 	Element for measurement and recovery of condensates, flue, (537D6226)	<ul style="list-style-type: none"> • Weather Slate Steep 25°-45° (537D6209) • Bracket Ø 150 mm (537D6210) • Weather Slate, Flat roof (Ø 430 mm) (537D6208) 	Concentric to parallel adapter Ø 100/150 mm - 2 x Ø 100 mm (537D6207)

* Designations and references (between brackets) are provided as information only. Please refer to the latest ACV Price list for more information and the correct references.

ELECTRICAL CHARACTERISTICS HEATMASTER® 25-35-45 TC

Main Characteristics	HeatMaster TC			
		25	35	45
Rated voltage	V~	230	230	230
Rated frequency	Hz	50	50	50
Electrical consumption	Max.	W	95	111
	Min.	W	19	30
Electrical consumption at 30% load	W	24	34	45
Electrical consumption in standby	W	3	3	3
Rated current (Fuse)	A	16	16	16
Class		IP 20	IP 20	IP 20

CABLE ROUTING

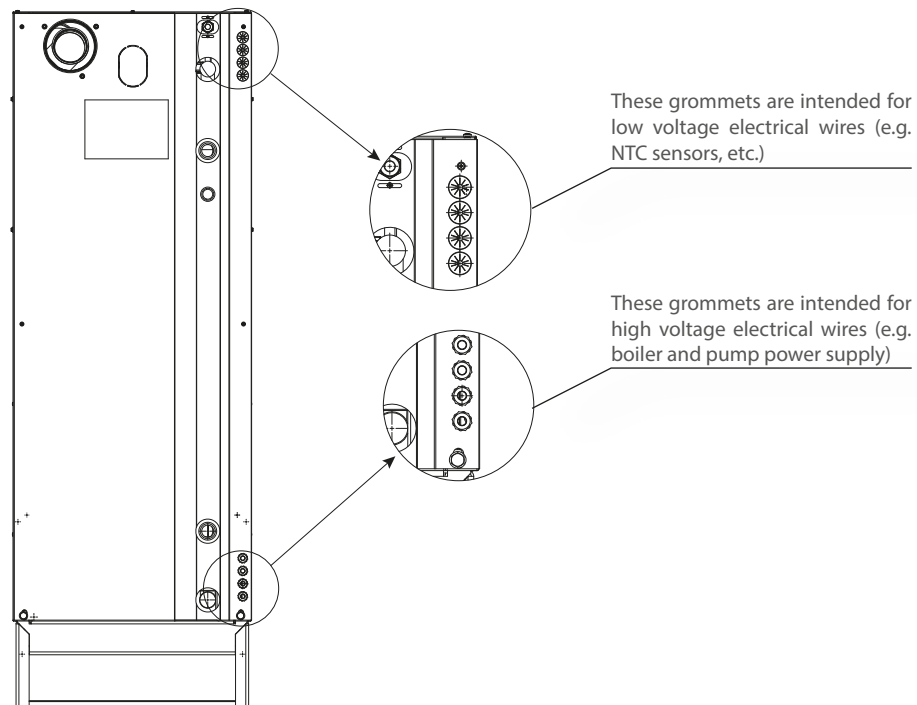

Key

1. 230 V power supply plug
2. Ground
3. ON/OFF master switch
4. Gas valve rectified
5. Burner power supply
6. Terminal block for optional items

 : Alarm (ERR)  **230 VAC OUTPUT !**

 : DHW circuit circulator pump (DHW)

7. Terminal block for optional items:

 : Pump (P3 and P4 terminals)

 : Flame terminal (versatile connection according to configuration)  **230 VAC OUTPUT !**

8. Modulating pump PWM
9. Burner PWM plug
10. NTC5 flue gas temperature sensor
11. NTC2 return sensor
12. NTC1 supply sensor
13. NTC - Low temperature circuit
14. High limit switch
15. Low water pressure sensor
16. PCB (Display)
17. ACVMax programming plug
18. A & B Modbus (option)
19. NTC3 DHW sensor
20. NTC4 outdoor temperature sensor (option)
21. Room thermostat 1 (option)
22. 0-10 Volt (option)
23. Room thermostat 2 (option)
24. Connection for interface control unit
25. Ignition and ionization cable
26. 5AT slow-blow fuse (3x) for internal and optional circuits*

* 5AT slow-blow fuse (2x) for internal circuits and connection of CH, DHW and Flame output + 5AT slow-blow fuse (1x) for connection of Alarm, P3 and P4 (connector P14)

 2 spare 5AT slow-blow fuses are located on the back side of the electrical box, for fuse replacement, if required.

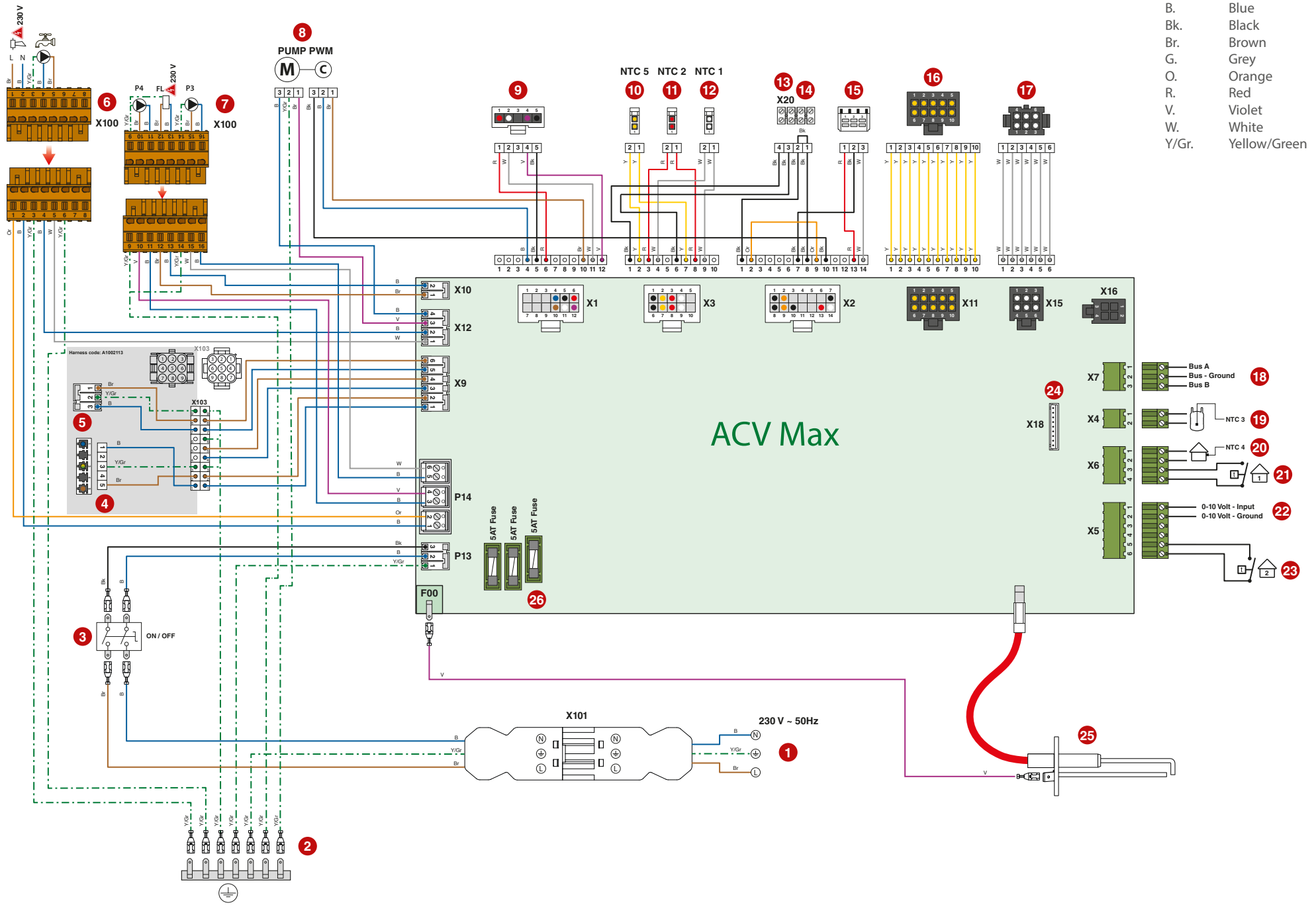

ELECTRICAL CHARACTERISTICS HEATMASTER® 70-85 TC

Main Characteristics	HeatMaster TC		
		70	85
Rated voltage	V~	230	230
Rated frequency	Hz	50	50
Electrical consumption	Max.	W	210
	Min.	W	50
Electrical consumption at 30% load	W	55	51
Electrical consumption in standby	W	3	3
Rated current (Fuse)	A	16	16
Class		IP 20	IP 20

Key

- 230 V power supply plug
- Ground
- ON/OFF master switch
- Gas valve
- Burner power supply
- Terminal block for optional items



: Alarm (ERR terminal)  230 VAC OUTPUT !



: DHW circuit circulator pump (DHW terminal)

- Terminal block for optional items:



: Pump (P3 and P4 terminals)



: Flame terminal (versatile connection according to configuration)  230 VAC OUTPUT !

- Burner PWM plug
- NTC5 flue gas temperature sensor
- NTC2 return sensor
- NTC1 supply sensor
- Gas pressure switch
- NTC - Low temperature circuit
- High limit switch
- Low water pressure sensor
- PCB (Display)
- ACVMax programming plug
- A & B Modbus (option)
- NTC3 DHW sensor
- NTC4 outdoor temperature sensor (option)
- Room thermostat 1 (option)
- 0-10 Volt (option)
- Room thermostat 2 (option)
- Ignition and ionization cable
- Connection for Interface Control Unit (option)
- 5AT slow-blow fuse (3x) for internal and optional circuits*
- Modulating pump PWM

* 5AT slow-blow fuse (2x) for internal circuits and connection of CH, DHW and Flame output + 5AT slow-blow fuse (1x) for connection of Alarm, P3 and P4 (connector P14).



2 spare 5AT slow-blow fuses are located on the back side of the electrical box, for fuse replacement, if required.

ELECTRICAL CHARACTERISTICS HEATMASTER® 120 TC

		HeatMaster TC
Main Characteristics		120
Rated voltage	V~	230
Rated frequency	Hz	50
Electrical consumption	Max.	W 327
	Min.	W 70
Electrical consumption at 30% load	W	74
Electrical consumption in standby	W	4
Rated current (Fuse)	A	16
Class		IP 20

Key

1. 230 V power supply plug
2. Ground
3. ON/OFF master switch
4. Gas valve
5. Burner power supply
6. Terminal block for optional items



: Alarm (ERR terminal)  **230 VAC OUTPUT !**



: DHW circuit circulator pump (DHW terminal)



7. Terminal block for optional items:



: Pump (P3 and P4 terminals)



: Flame terminal (versatile connection according to configuration)  **230 VAC OUTPUT !**

8. Burner PWM plug
9. NTC5 flue gas temperature sensor
10. NTC2 return sensor
11. NTC1 supply sensor
12. Gas pressure switch
13. NTC - Low temperature circuit
14. High limit switch
15. Low water pressure sensor
16. PCB (Display)
17. ACVMax programming plug
18. A & B Modbus (option)
19. NTC3 DHW sensor
20. NTC4 outdoor temperature sensor (option)
21. Room thermostat 1 (option)
22. 0-10 Volt (option)
23. Room thermostat 2 (option)
24. Ignition and ionization cable
25. Connection for Interface Control Unit (option)
26. 5AT slow-blow fuse (3x) for internal and optional circuits*
27. Modulating pump PWM

* 5AT slow-blow fuse (2x) for internal circuits and connection of CH, DHW and Flame output + 5AT slow-blow fuse (1x) for connection of Alarm, P3 and P4 (connector P14).



2 spare 5AT slow-blow fuses are located on the back side of the electrical box, for fuse replacement, if required.

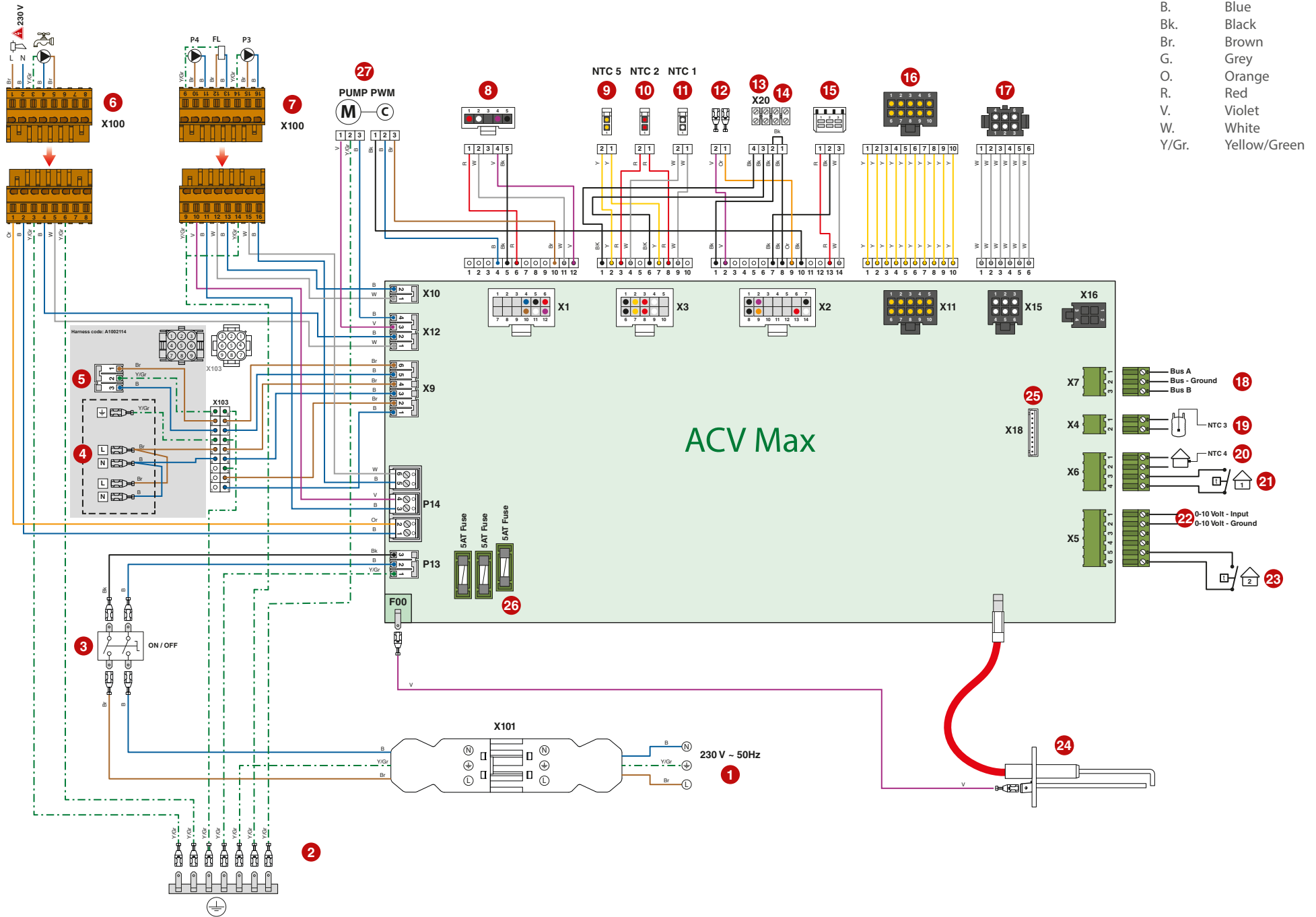

HYDRAULIC CHARACTERISTICS

		HEATMASTER TC					
Main Characteristics		25	35	45	70	85	120
Capacity (primary)	L	100	100	100	125	125	125
Capacity (DHW)	L	96	96	96	190	190	190
Water pressure drop (primary circuit) ($\Delta t = 20$ K)	mbar	3	6	10	9	14	27

HYDRAULIC PRESSURE DROP CURVE OF THE BOILERS

HeatMaster® 25 - 35 - 45 TC

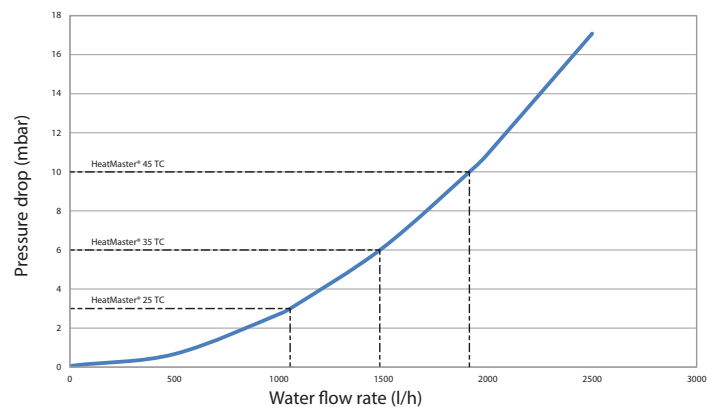

HeatMaster® 70 - 85 - 120 TC

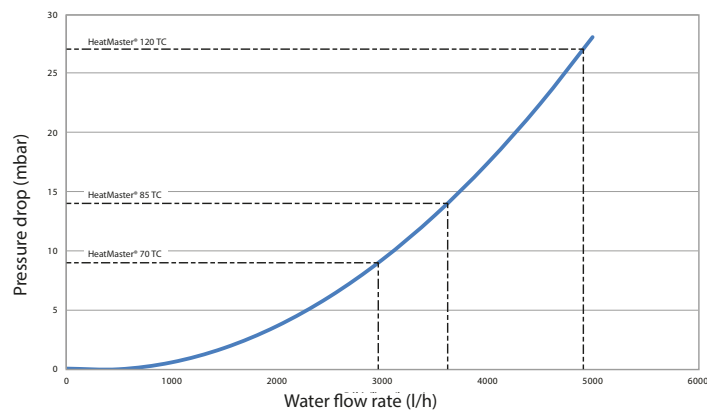

DHW PERFORMANCE

Domestic hot water performance* (cold drink water at 10°C)

Operating conditions at 80°C			HM 25 TC	HM 35 TC	HM 45 TC
Constant flow at	40 °C [$\Delta T = 30$ K]	L/h	788	1,104	1,390
	45 °C [$\Delta T = 35$ K]	L/h	676	946	1,192
	60 °C [$\Delta T = 50$ K]	L/h	473	662	820
Peak flow at	40 °C [$\Delta T = 30$ K]	L/10'	361	408	471
	45 °C [$\Delta T = 35$ K]	L/10'	301	339	373
	60 °C [$\Delta T = 50$ K]	L/10'	183	197	320
Peak flow 1st hour at	40 °C [$\Delta T = 30$ K]	L/60'	1,018	1,328	1,610
	45 °C [$\Delta T = 35$ K]	L/60'	865	1,127	1,366
	60 °C [$\Delta T = 50$ K]	L/60'	577	749	894
Reheat time from 10°C to 80°C	min.	35	26	23	
DHW efficiency at $\Delta T = 30$ K	%	105.4	105.4	103.1	

Domestic hot water performance* (cold drink water at 10°C)

Operating conditions at 80°C			HM 70 TC	HM 85 TC	HM 120 TC
Constant flow at	40 °C [$\Delta T = 30$ K]	L/h	2,087	2,534	3,402
	45 °C [$\Delta T = 35$ K]	L/h	1,789	2,172	2,928
	60 °C [$\Delta T = 50$ K]	L/h	1,252	1,520	1,754
Peak flow at	40 °C [$\Delta T = 30$ K]	L/10'	716	783	900
	45 °C [$\Delta T = 35$ K]	L/10'	592	646	676
	60 °C [$\Delta T = 50$ K]	L/10'	348	371	440
Peak flow 1st hour at	40 °C [$\Delta T = 30$ K]	L/60'	2,455	2,895	3,620
	45 °C [$\Delta T = 35$ K]	L/60'	2,083	2,456	3,098
	60 °C [$\Delta T = 50$ K]	L/60'	1,391	1,638	1,847
Reheat time from 10°C to 80°C	min.	27	24	23	
DHW efficiency at $\Delta T = 30$ K	%	103.9	103.9	102.2	

MAXIMUM OPERATING CONDITIONS

Maximum Service Pressure (tank full of water) *

- Primary circuit : 3 bar
- DHW circuit : 8.6 bar

Maximum Operating Temperatures

- Maximum temperature (primary) : 87°C
- Maximum temperature (DHW) : 75°C

Water Quality

See "Recommendations for the Prevention of Corrosion and Scaling in Heating Systems" on the following page.

* The hydraulics of the boiler have been tested according to EN-15502, and the boiler is classified as a pressure class 3 appliance.

RECOMMENDATIONS FOR THE PREVENTION OF CORROSION AND SCALING IN HEATING SYSTEMS

How oxygen and carbonates can affect the heating system

Oxygen and dissolved gasses in the water of the primary circuit contribute to the oxidation and the corrosion of the system components that are made of ordinary steel (radiators, ...). The resulting sludge is then deposited in the boiler exchanger.

The combination of carbonates and carbon dioxide in the water results in the formation of scale on the hot surfaces of the installation, including those of the boiler exchanger.

These deposits in the heat exchanger reduce the water flow rate and thermally insulate the exchange surfaces, which is likely to damage them.

Sources of oxygen and carbonates in the heating circuit

The primary circuit is a closed circuit; the water it contains is therefore isolated from the mains water. When maintaining the system or filling up the circuit, water renewal results in the addition of oxygen and carbonates in the primary circuit. The larger the water volume in the system, the larger the addition.

Hydraulic components without an oxygen barrier (PE pipes and connections) admit oxygen into the system.

Prevention Principles

1. Clean the existing system before installing a new boiler

- Before the system is filled, it must be cleaned in accordance with standard EN14336. Chemical cleaning agents can be used.
- If the circuit is in bad condition, or the cleaning operation was not efficient, or the volume of water in the installation is substantial (e.g. cascade system), it is recommended to separate the boiler from the heating circuit using a plate-to-plate exchanger or equivalent. In that case, it is recommended to install a hydrocyclone or magnetic filter on the installation side.

2. Limit the fill frequency

- Limit fill operations. In order to check the quantity of water that has been added into the system, a water meter can be installed on the filling line of the primary circuit.
- Automatic filling systems are not recommended.
- If your installation requires frequent water refilling, make sure your system is free of water leaks.
- Inhibitors may be used in accordance with standard EN 14868.

3. Limit the presence of oxygen and sludge in the water

- A deaerator (on the boiler flow line) combined with a dirt separator (upstream of the boiler) must be installed according to the manufacturer's instructions.
- ACV recommends using additives that keep the oxygen in solution in the water, such as Fernox (www.fernox.com) and Sentinel (www.sentinel-solutions.net) products.
- The additives must be used in accordance with the instructions issued by the manufacturer of the water treatment product.

4. Limit the carbonate concentration in the water

- The fill water must be softened if its hardness is higher than 20° fH (11,2° dH).
- Check regularly the water hardness and enter the values in the service log.
- Water hardness table :

Water hardness	°fH	°dH	mmolCa(HCO3)2 / l
Very soft	0 - 7	0 - 3.9	0 - 0.7
Soft	7 - 15	3.9 - 8.4	0.7 - 1.5
Fairly hard	15 - 25	8.4 - 14	1.5 - 2.5
Hard	25 - 42	14 - 23.5	2.5 - 4.2
Very hard	> 42	> 23.5	> 4.2

5. Control the water parameters

- In addition to the oxygen and the water hardness, other parameters of the water must be checked.
- Treat the water if the measured values are outside the range.

Acidity	6,6 < pH < 8,5
Conductivity	< 400 µS/cm (at 25°C)
Chlorides	< 125 mg/l
Iron	< 0,5 mg/l
Copper	< 0,1 mg/l

G3 REQUIREMENTS AND GUIDANCE - UK ONLY

UK

Discharge pipe from safety valves

The *Building Regulation G3* requires that any discharge from an unvented system is conveyed to where it is visible, but will not cause danger to persons in or about the building.

The tundish and discharge pipes should be fitted in accordance with the requirements and guidance notes of Building Regulation G3. The G3 Requirements and Guidance sections 3.50 - 3.63 are detailed below.

For discharge pipe arrangements not covered by G3 Guidance advice should be sought from your local Building Control Officer.

Main characteristics :

- Any discharge pipe connected to the pressure relief devices (Expansion Valve and Temperature/Pressure Relief Valve) must be installed in a continuously downward direction and in a frost free environment.
- Water may drip from the discharge pipe of the pressure relief device.
- This pipe must be left open to the atmosphere.
- The pressure relief device is to be operated regularly to remove lime deposits and to verify that it is not blocked.

A typical discharge pipe arrangement is shown on next page.



General remarks

- Discharge pipe-work D2 can now be a plastic pipe but only pipes that have been tested to a minimum 110°C must be used.
- Discharge pipe D2 can now be plumbed into the soil stack but only soil stacks that can handle temperatures of 99°C or greater should be used.

Extract from "The Building Regulation G3" :

Discharge pipe D1

- 3.50 *Safety devices such as temperature relief valves or combined temperature and pressure and pressure relief valves (see paragraphs 3.13 or 3.18) should discharge either directly or by way of a manifold via a short length of metal pipe (D1) to a tundish.*
- 3.51 *The diameter of discharge pipe (D1) should be not less than the nominal outlet size of the temperature relief valve.*
- 3.52 *Where a manifold is used it should be sized to accept and discharge the total discharge from the discharge pipes connected to it.*
- 3.53 *Where valves other than the temperature and pressure relief valve from a single unvented hot water system discharge by way of the same manifold that is used by the safety devices, the manifold should be factory fitted as part of the hot water storage system unit or package.*

Tundish

- 3.54 *The tundish should be vertical, located in the same space as the unvented hot water storage system and be fitted as close as possible to, and lower than, the valve, with no more than 600mm of pipe between the valve outlet and the tundish.*

Note: *To comply with the Water Supply (Water Fittings) Regulations, the tundish should incorporate a suitable air gap.*

- 3.55 *Any discharge should be visible at the tundish. In addition, where discharges from safety devices may not be apparent, e.g. in dwellings occupied by people with impaired vision or mobility, consideration should be given to the installation of a suitable safety device to warn when discharge takes place, e.g. electronically operated.*

UK

Discharge pipe D2

- 3.56 *The discharge pipe (D2) from the tundish should:*
 (a) *have a vertical section of pipe at least 300mm long below the tundish before any elbows or bends in the pipework; and*
 (b) *be installed with a continuous fall thereafter of at least 1 in 200.*
- 3.57 *The discharge pipe (D2) should be made of:*
 (a) *metal; or*
 (b) *other material that has been demonstrated to be capable of safely withstanding temperatures of the water discharged and is clearly and permanently marked to identify the product and performance standard (e.g. as specified in the relevant part of BS 7291)*
- 3.58 *The discharge pipe (D2) should be at least one pipe size larger than the nominal outlet size of the safety device unless its total equivalent hydraulic resistance exceeds that of a straight pipe 9m long, i.e. for discharge pipes between 9m and 18m the equivalent resistance length should be at least two sizes larger than the nominal outlet size of the safety device; between 18 and 27m at least 3 sizes larger, and so on; bends must be taken into account in calculating the flow resistance. See figure, table and the worked example.*
- 3.59 *Where a single common discharge pipe serves more than one system, it should be at least one pipe size larger than the largest individual discharge pipe (D2) to be connected.*
- 3.60 *The discharge pipe should not be connected to a soil discharge stack unless it can be demonstrated that the soil discharge stack is capable of safely withstanding temperatures of the water discharged, in which case, it should:*
 (a) *contain a mechanical seal, not incorporating a water trap, which allows water into the branch pipe without allowing foul air from the drain to be ventilated through the tundish;*
 (b) *be a separate branch pipe with no sanitary appliances connected to it;*
 (c) *if plastic pipes are used as branch pipes carrying discharge from a safety device they should be either polybutylene (PB) to Class S of BS 7291-2:2006 or cross linked polyethylene (PE-X) to Class S of BS 7291-3:2006; and (d) be continuously marked with a warning that no sanitary appliances should be connected to the pipe.*

Note:

1. *Plastic pipes should be joined and assembled with fittings appropriate to the circumstances in which they are used as set out in BS EN ISO 1043-1.*
2. *Where pipes cannot be connected to the stack it may be possible to route a dedicated pipe alongside or in close proximity to the discharge stack.*

Termination of discharge pipe

- 3.61 *The discharge pipe (D2) from the tundish should terminate in a safe place where there is no risk to persons in the vicinity of the discharge.*
- 3.62 *Examples of acceptable discharge arrangements are:*
 (b) *to a trapped gully with the end of the pipe below a fixed grating and above the water seal;*
 (c) *downward discharges at low level; i.e. up to 100mm above external surfaces such as car parks, hard standings, grassed areas etc. are acceptable providing that a wire cage or similar guard is positioned to prevent contact, whilst maintaining visibility; and*
 (d) *discharges at high level: e.g. into a metal hopper and metal downpipe with the end of the discharge pipe clearly visible or onto a roof capable of withstanding high temperature discharges of water and 3m from any plastic guttering system that would collect such discharges.*

3.63 The discharge would consist of high temperature water and steam. Asphalt, roofing felt and non-metallic rainwater goods may be damaged by such discharges.

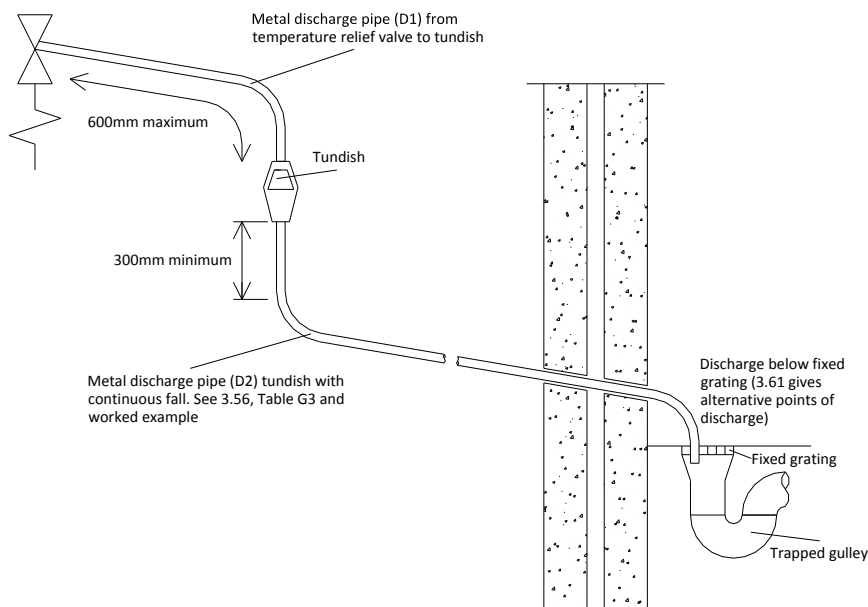

Figure G3: Typical discharge pipe arrangement

Table G3 – Sizing of copper discharge pipe ‘D2’ for common temperature relief valve outlet sizes

Valve outlet size	Minimum size of discharge pipe D1	Minimum size of discharge pipe D2 from tundish	Maximum resistance allowed, expressed as a length of straight pipe (i.e. no elbows or bends)	Resistance created by each elbow or bend.
G½	15mm	22mm	Up to 9m	0.8m
		28mm	Up to 8m	1.0m
		35mm	Up to 27m	1.4m
G¾	22mm	28mm	Up to 9m	1.0m
		35mm	Up to 8m	1.4m
		42mm	Up to 27m	1.7m
G1	28mm	35mm	Up to 9m	1.4m
		42mm	Up to 8m	1.7m
		54mm	Up to 27m	2.3m

Worked example of discharge pipe sizing



Figure on the left shows a G1/2 temperature relief valve with a discharge pipe (D2) having 4 No. elbows and length of 7m from the tundish to the point of discharge.

From Table:

Maximum resistance allowed for a straight length of 22mm copper discharge pipe (D2) from a G1/2 temperature relief valve is 9.0m.

- Subtract the resistance for 4 No. 22mm elbows at 0.8m each = 3.2m
- Therefore the permitted length equates to: 5.8m
- 5.8m is less than the actual length of 7m therefore calculates the next largest size.

Maximum resistance allowed for a straight length of 28mm pipe (D2) from a G1/2 temperature relief valves equates to 18m.

- Subtract the resistance of 4 No. 28mm elbows at 1.0m each = 4.0m
- Therefore the maximum permitted length equates to: 14m
- As the actual length is 7m, a 28mm (D2) copper pipe will be satisfactory.



Essential recommendations for safety

- The temperature/pressure relief valve should only be replaced by a competent person.
- No control or safety valves should be tampered with or used for any other purpose.
- The discharge pipe should not be blocked or used for any other purpose.
- The tundish should not be located adjacent to any electrical components



Essential recommendations for safety

- Install the boiler on level base or vertically plumb support made of combustible materials and of sufficient strength to support its weight.
- Use extreme care not to drop the boiler or cause bodily injury while lifting the boiler onto the wall bracket or base. Once mounted, verify that the boiler is securely attached to the bracket and wall or safely set on its base.
- Do not use or store any flammable or corrosive products, such as paint, solvents, salts, chloride products and other detergent products near the appliance.
- Make sure that the condensate outlet is never obstructed and that a condensate neutralisation system is installed if required.
- Make sure that all air vents are unobstructed at all times.
- In the event of small amounts of hot water repeatedly being drawn, a stratification effect can develop in the tank. The upper hot water layer may reach very high temperatures.
- Hot water can cause scalding! The temperature of the domestic hot water should be adjusted up to 75 °C in the boiler. However, the temperature of the domestic hot water at the drawing off point must comply with local regulations.
- The risk of developing bacteria exists, including "Legionella pneumophila", if a minimum temperature of 60°C is not maintained in both the DHW tank and the hot water distribution network.
- In order to avoid exposure to extremely hot water that can cause serious burns, leave children, old people, disabled or handicapped people in the bath or shower alone. Never allow young children to turn on the hot water or fill their own bath.
- ACV recommends using a pre-set thermostatic mixing valve in order to prevent drawing off hot water at a maximum of 60°C.



Essential recommendations for the electrical safety

- Only an approved installer is authorized to carry out the electrical connections.
- Make sure that the appliance is connected to the earth.
- Install a 2-way switch and a fuse or circuit breaker of the recommended rating outside the appliance, so as to be able to shut power down when servicing the appliance or before performing any operation on it.
- Isolate the external electrical supply of the appliance before performing any operation on the electrical circuit.
- This appliance is not intended for use by persons (including children) with reduced physical, sensory or mental capabilities, or lack of experience and knowledge, unless supervised or unless they have been given instruction concerning the use of the appliance by a person responsible for their safety.



Essential recommendations for the correct operation of the appliance

- The connections (electrical, flue pipe, hydraulic) must be carried out in accordance with local standards and regulations in force.
- The boiler must be installed in a dry and protected area, with an ambient temperature comprised between 0 and 45°C.
- Install the appliance to ensure easy access at all times.
- To avoid any risk of corrosion, connect the stainless steel DHW production tank directly to the earth.
- Make sure that the mains water used to fill the boiler has a minimum pressure of 1.2 bar.
- Make sure to install a pressure reducing valve set at 4.5 bar if the mains supply pressure is in excess of 6 bar.
- The DHW circuit must be fitted with an approved safety group, comprised of a 7 bar safety valve, a check valve and a shut-off valve.
- If works need to be performed (in the boiler room or close to the air vents), make sure to turn off the boiler to prevent dust from entering and accumulating in the boiler heating system.



General remark

- If the water drawing off point is far from the tank, installing an auxiliary DHW loop can allow to get hot water more quickly at all times.

* For UK specific requirements for the discharge from safety valves, refer to «G3 Requirements and Guidance - UK Only» on page 32.

PACKAGE CONTENTS

The HeatMaster® 25 - 35 - 45 - 70 - 85 - 120 TC boilers are delivered assembled and packaged.



At product reception and after removal of packaging, check the package contents and that the appliance is free of damages.

Contents

- Boiler
- Installation, Operation and Maintenance Instructions
- Orifice for the natural gas to propane conversion + sticker
- Ball condensate trap to be installed.
- Base front panel to be installed
- Safety valve kit to be installed, comprised of:
 - A primary safety valve Ø 1/2" F



TOOLS REQUIRED FOR THE INSTALLATION

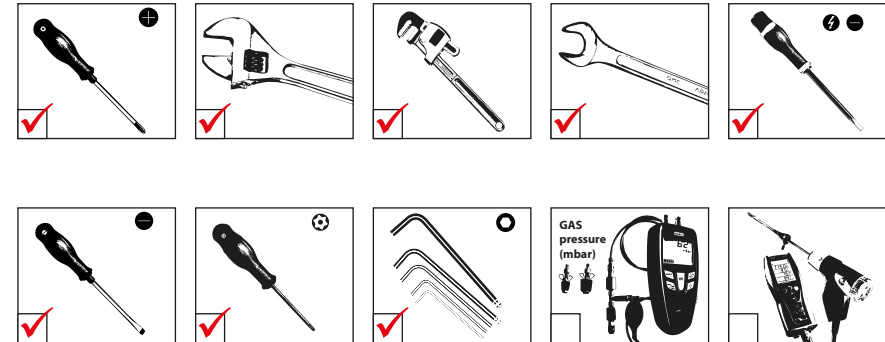

BOILER PREPARATION

Before placing the boiler in its final position:

- Close the circulation tube end tap (1) (access from the bottom of the boiler)
 - The circulation tube is equipped with an end tap that is open when the boiler is delivered (to prevent test water from being stuck in the circuit and freezing during transport). Make sure that you close the tap before filling the system with water.
- Install the ball condensate trap, then the base front panel (to be clipped in)
- Install the safety valve kit: Primary circuit safety valve at the back of the boiler

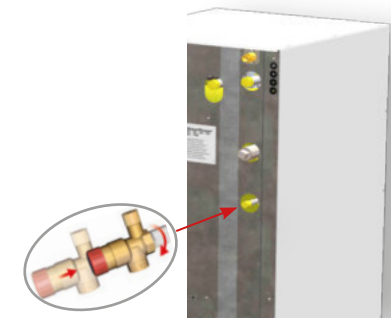
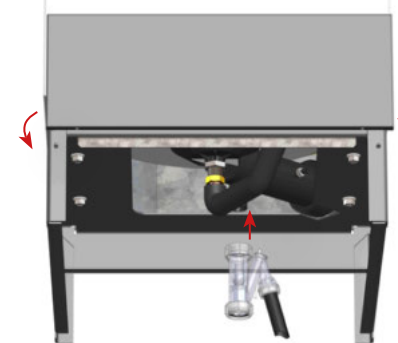
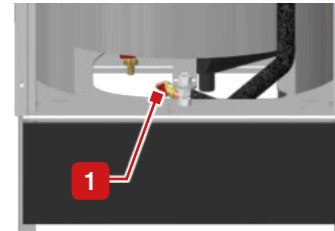

Fit the condensate trap, complete with the ball, making sure to install the items in the correct sequence and connect the hose to the drain using a connection that can be inspected. Fill the trap with clean water. Make sure to prevent any risk of the condensates freezing.

RECOMMENDATIONS FOR HYDRAULIC CONNECTIONS



Essential recommendations for safety

- If the boiler is not equipped with one, the heating circuit of the system must be fitted with an approved safety pressure relief valve, according to the pressure mentioned on the type plate.
- Use a two-wrench method when tightening field piping onto the boiler piping connections. Use one wrench to prevent the boiler connections from turning and the second to tighten field piping. Failure to support the boiler piping connections could damage piping or cause a leak.



Essential recommendations for the correct operation of the appliance

- If the boiler is not equipped with one, make sure to install an expansion vessel in the primary circuit, which is adapted to the boiler power/size and the type of system.



General remark

- The circuit illustrations are basic principle diagrams only.

RECOMMENDATIONS FOR DHW CONNECTIONS



Essential recommendations for safety

- The hot water output may reach temperatures in excess of 60°C, which can cause scalding! It is therefore necessary to install a thermostatic mixing valve after the appliance.
- The system must be fitted with an approved safety group, comprised of a 7 bar safety valve, a check valve and a shut-off valve.*



Essential recommendations for the correct operation of the appliance

- Flush the system before connecting the domestic hot water circuit. Refer to the installation instructions.
- Make sure to install a pressure reducing valve set at 4.5 bar if the mains supply pressure is in excess of 6 bar.
- It is recommended to install an expansion vessel in the DHW circuit to prevent the safety valve from opening constantly and reduce the water hammer effect in the system.
- If the appliance is used as a domestic hot water preparation tank, a primary expansion vessel adapted to the boiler power/size and to the type of system must be fitted in the heating circuit (if there is no built-in expansion vessel, or if the built-in expansion vessel size is not sufficient).

DHW CONNECTION

Description

1. Isolating valve
2. Pressure reducing valve
3. Check valve
4. DHW expansion vessel
5. Safety valve
6. Drain valve
7. Grounding
8. Draw-off tap
9. Thermostatic mixing valve

— Cold water
— Hot water

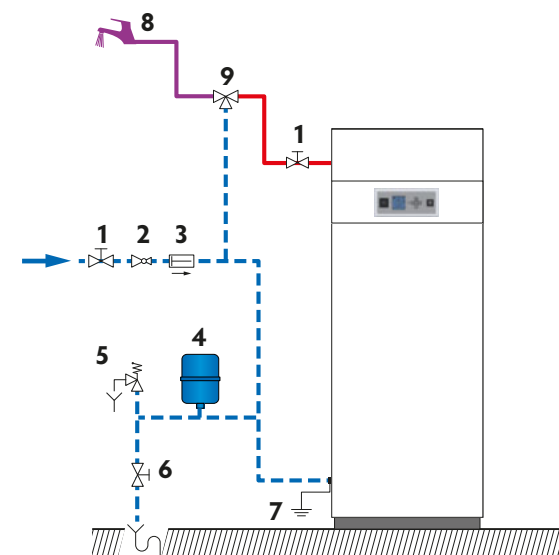

* For UK specific requirements for the discharge from safety valves, refer to «G3 Requirements and Guidance - UK Only» on page 32.

HEATING CONNECTION

Typical connection - high temperature

Description

1. Isolating valve
2. Heating pump
3. Filling valve
4. Check valve
5. Safety valve
6. Expansion vessel
7. Drain valve
8. Automatic air vent (built-in)

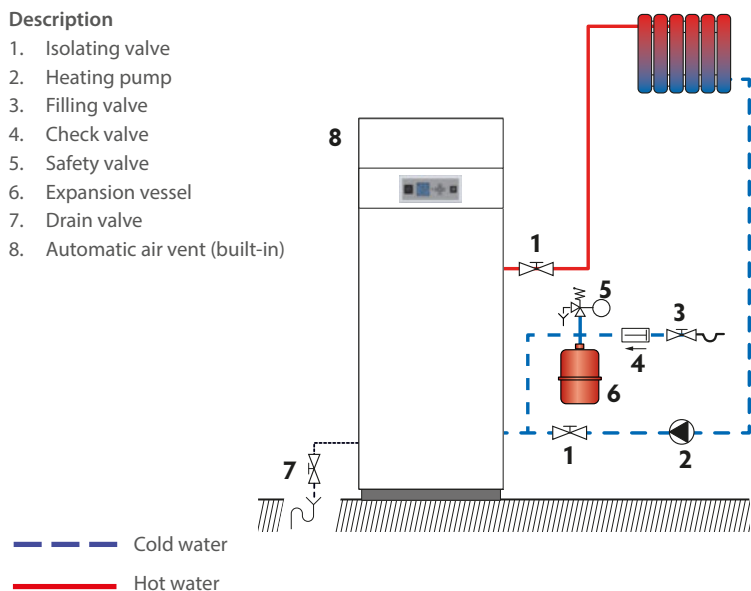

Typical connection - low temperature

Description

1. Isolating valve
2. 3-way mixing valve
3. Heating pump
4. Safety valve
5. Filling valve
6. Check valve
7. Expansion vessel
8. Drain valve
9. Automatic air vent (built-in)

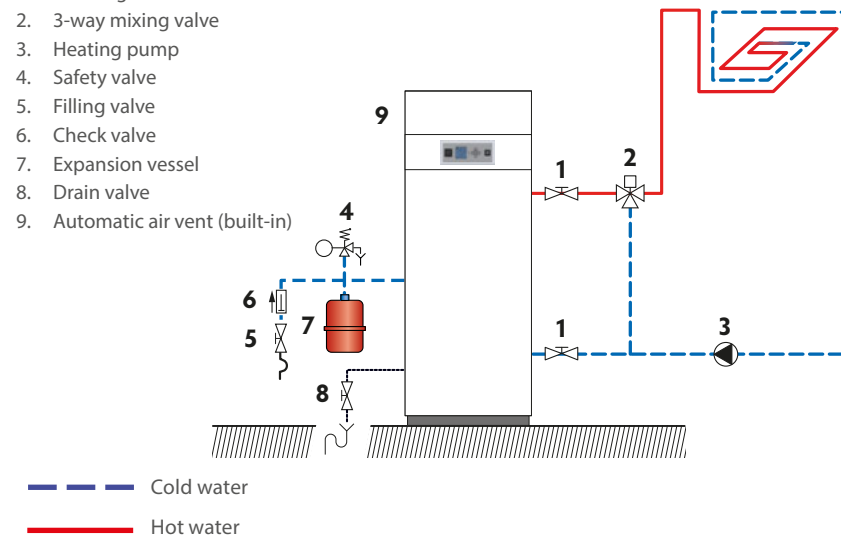

Optional accessories to control a regular low temperature heating circuit. For more information, refer to the Installer's Handbook.

Accessory	Description
Room thermostat	
Contact thermostat	Mandatory to protect all floor heating circuits.
Low temperature kit DN 25 (HM 25 / 35 / 45 TC)	Includes a heating pump, two isolating valves, a check valve, two thermometers, a 3-way valve with built-in bypass and a servomotor.
Low temperature kit DN 32 (HM 70 / 85 / 120 TC)	Includes a heating pump, two isolating valves, a check valve, two thermometers and a 3-way valve with built-in bypass.
Servomotor	Motor for the 3-way valve provided with the low temperature kit.



Optional accessories to control a regular high temperature heating circuit. For more information, refer to the Installer's Handbook.

Accessory	Description
Room thermostat	
High temperature kit DN 25 (HM 25 / 35 / 45 TC)	Includes a heating pump, two isolating valves, a check valve and two thermometers.
High temperature kit DN 32 (HM 70 / 85 / 120 TC)	Includes a heating pump, two isolating valves, a check valve and two thermometers.



For additional system configurations, refer to "Configuration and system set-up" on page 44 and to the Installer's Handbook.

REMOVAL AND INSTALLATION OF THE FRONT AND TOP PANELS

Set-up conditions

- External power supply isolated

Removal Procedure

Upper front panel

1. Release two bolts (1), one on the left and one on the right. Retain for reinstallation
2. Pull the top of the panel towards you to disengage the upper studs.

Lower front panel

1. Release two bolts (2), one on the left and one on the right. Retain for reinstallation
2. Pull the bottom of the panel towards you to disengage the lower studs.

Top panel

1. Release 7 screws and retain them for reinstallation.
2. Remove top panel.

Installation procedure

Top panel

1. Put top panel in position on the boiler.
2. Install and tighten 7 screws.

Lower front panel

1. Push panel in position, engaging the studs in their corresponding slots until a "click" is heard.
2. Install both bolts (2) and tighten them.

Upper front panel

1. Push panel in position, engaging the studs in their corresponding slots until a "click" is heard.
2. Install both bolts (1) and tighten them.

Follow-on tasks

None

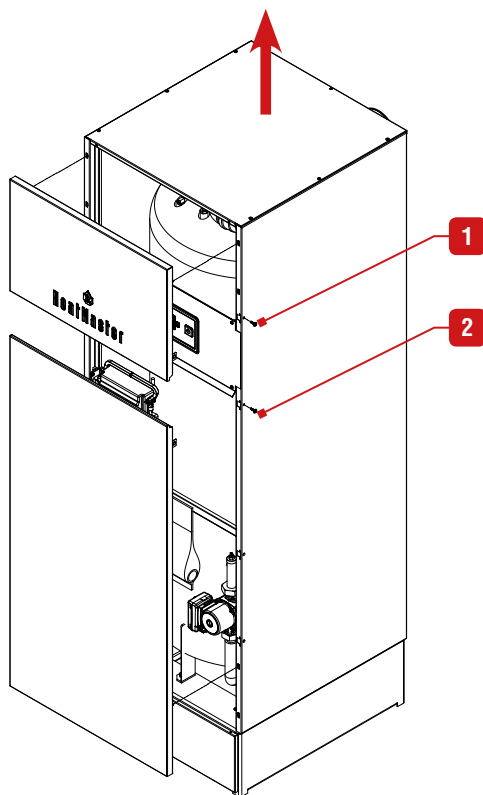

RECOMMENDATIONS FOR GAS CONNECTION



Essential recommendations for safety

- The gas connection must comply with all applicable local standards and regulations, and the circuit will be equipped with a gas pressure regulator as required.
- Do not check for gas leaks with an open flame. Use a gas detection device or bubble test.
- The gas burners are factory preset for use with natural gas [equivalent to G20]. Do not adjust or attempt to measure gas valve outlet pressure. The gas valve is factory-set for the correct outlet pressure and requires no field adjustment.
- The natural gas to propane conversion or the reverse is not authorized in certain countries such as Belgium. Refer to the table of gas categories in the technical characteristics of this manual.
- The gas orifice installed on the boiler must never be modified or replaced with a different size orifice, except in the case of a gas conversion process, which shall be performed according to the provided procedure and requirements.
- The CO₂, gas flow rate, air flow rate and air/gas supply parameters are factory-preset and may not be modified in Belgium, except for type I 2E(R)B boilers.
- Do not change the OFFSET (A) setting of the gas valve: it is factory-preset and sealed.

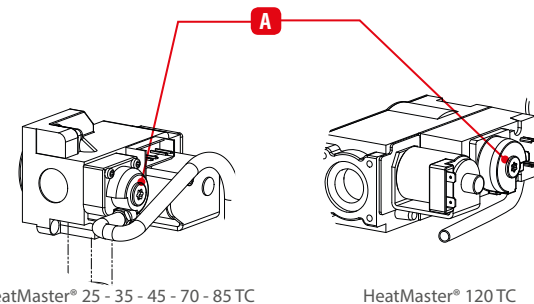

Essential recommendations for the correct operation of the appliance

- Refer to the technical characteristics of this manual or to the burner documentation to know the connection diameters.
- Bleed the gas duct and check thoroughly if all the boiler tubes, both internal and external, are tight.
- Check that the gas type and pressure from the distribution network are compatible with the appliance settings. Refer to the product type plate.
- Check the boiler electrical connection, the boiler room air vent system, the tightness of flue gas outlet pipes and of the burner chamber plate.
- Control the gas pressure and consumption at appliance start up.
- Check the boiler CO₂ adjustment (refer to the adjustment procedure and the technical data).

CONVERSION TO PROPANE



General remark

- According to the indication on the type plate, the boiler is factory preset to operate with natural gas (G20/G25). Converting the boiler to propane is done through the installation of an orifice and adjustments. The conversion is prohibited in Belgium.

Set-up conditions

- External power supply isolated
- Gas supply closed
- Upper front panel and top panel of the boiler open, refer to "Removal and Installation of the Front and Top Panels" on page 42

Procedure of orifice installation (HM 25 - 35 - 45 - 70 - 85 TC)

1. Unscrew the gas pipe.
2. Remove the plug from the gas valve (1).
3. Disconnect the air inlet (2) from the venturi (3).
4. Remove the gas valve/venturi assembly by releasing two screws (5). Retain the screws for reinstallation.
5. Remove the gas valve (1) from the venturi (3) by releasing 3 screws (4). Retain the screws for reinstallation.
6. Install the orifice in the center of the O-ring (6).

Make sure you position the O-ring correctly.

7. Reassemble the gas valve/venturi assembly, following the same procedure in reverse order, and torque the 3 gas valve screws (4) and the 2 venturi screws (5). Refer to "Torque Values" on page 51.
8. Reinstall the air inlet (2).

Procedure of orifice installation (HM 120 TC)

1. Remove the plugs from the gas valve (1).
2. Unscrew the union (4) of the gas pipe.
3. Release 4 screws from the gas pipe flange (3) and retain for reinstallation.
4. Install the orifice in the flange (3).

Make sure you position the orifice correctly (shouldered face turned towards the gas pipe, flat face turned towards the gas valve).

5. Install the O-ring (2) on the flange.
6. Install the flange (3) on the gas valve (1) using 4 retained screws.

HeatMaster TC	Propane orifice dia. (mm)
25 - 35	5.2
45	6.0
70 - 85	6.8
120	8.6

Follow-on tasks

- Stick the sticker provided with the conversion kit on the boiler and check the box to indicate the type of gas to be now used with the boiler.
- Reconnect the gas pipe connection.
- Reconnect the plug(s) to the gas valve (1).
- Restart the boiler.
- Change the boiler code through the Installer menu, refer to the "Installer's handbook"
- Carry out the CO₂ adjustment, (refer to "Checking and Adjusting the Burner" on page 47).
- Reseal the offset and the throttle on the gas valve (1), as required.

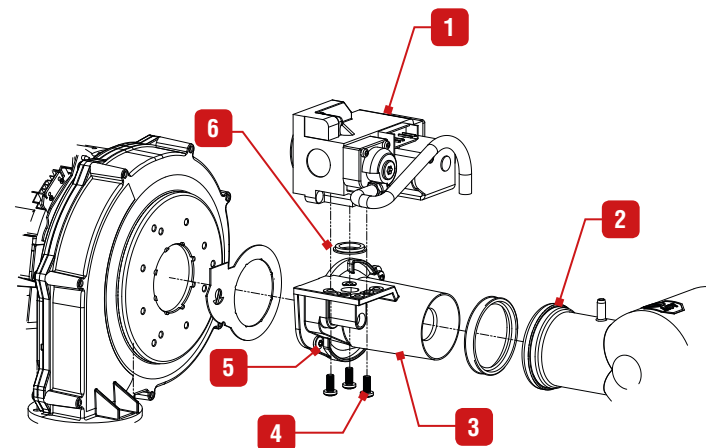

HeatMaster 25 - 35 - 45 - 70 - 85 TC

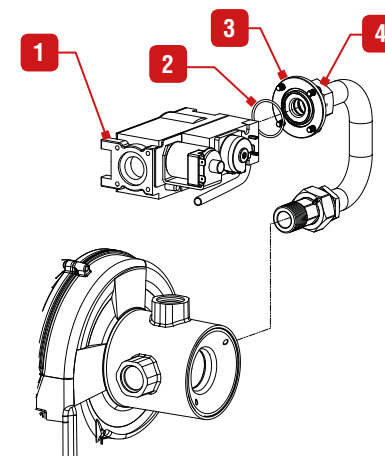

HeatMaster 120 TC

BASIC CONFIGURATION - HEATMASTER 25 TC V15: HIGH TEMPERATURE HEATING CIRCUIT CONTROLLED BY ROOM THERMOSTAT AND OPTIONAL OUTDOOR SENSOR.

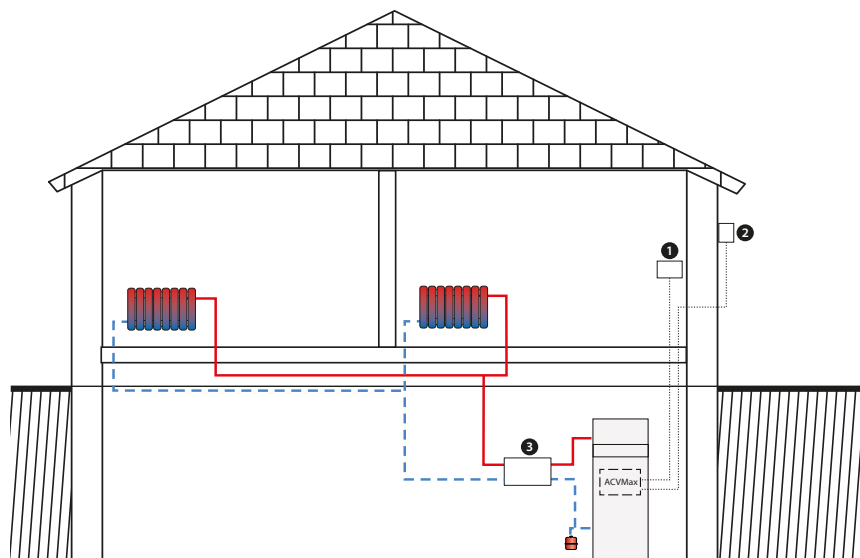

BLOCK DIAGRAM

The heating system (radiators) is controlled by an On/Off room thermostat.

In this configuration, the boiler constantly adapts its operation to the outdoor temperature, if an outdoor temperature sensor is connected.

The heating pump is triggered as soon as the room thermostat generates a heat demand.

The priority of the internal domestic hot water tank of the boiler (DHW circuit not shown here) is always active.

* The illustrations are for information only. For more details on the required accessories, refer to the latest ACV price list.

** For electrical detail, refer to wiring diagram in "Electrical Characteristics HeatMaster® 25-35-45 TC" on page 28.

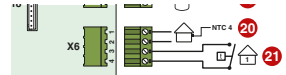
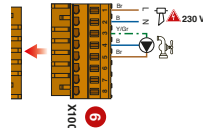
ITEM	DESCRIPTION	QTY	ELECT. TERMINALS TO CONNECT TO**
1	Room thermostat	1	X6 3&4 
2	Outdoor temperature sensor, 12kΩ	1	X6 1&2
	2 circuit manifold : Max power : 70 kW, With built-in wall mounts.	1	--
3	High temperature kit : Includes: a circulator pump, two isolation valves, a check valve and two thermometers.	2	 X100 3 to 8
	By-pass kit : To read the flow rate more easily. To be installed in the HT or LT circuit, as required.	1	--

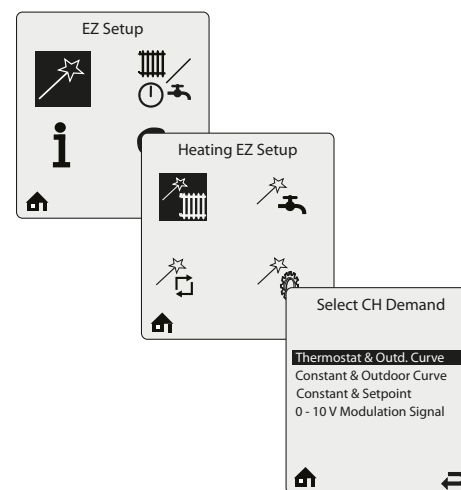

CASCADE CONFIGURATION, CONTROLLED BY EBV CONTROLLER

The control Unit (EBV Controller) is used to control a HeatMaster TC Cascade. The connection is made through the EBV Clip-in wiring provided with the Control Unit.

Please connect on ACVMax board X18 and route wires to EBV equipment.

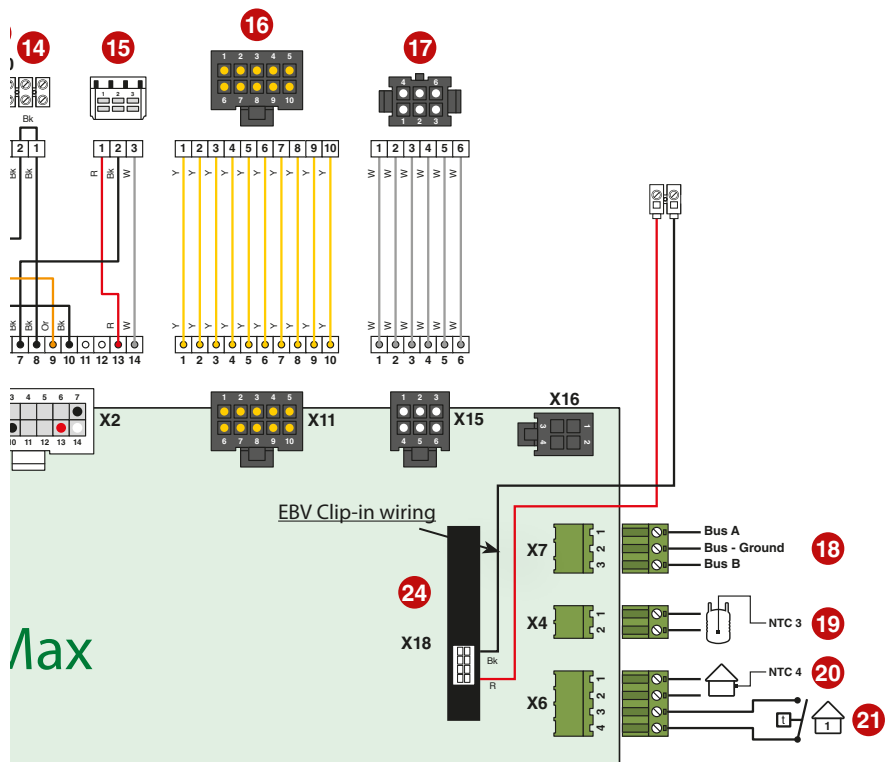

i For additional information and specific system configurations, please contact your ACV representative.

SAFETY INSTRUCTIONS FOR STARTING UP

Essential recommendations for safety

- The components inside the control panel may only be accessed by an approved installer.
- Set the water temperature in accordance with usage and local plumbing codes.
- Make sure that the heating circuit filling valve is closed once the starting up process is complete.
- If there is a drain assembly, make sure that the condensate drain assembly is filled with water before starting up the boiler. Fill with water as necessary.
- Make sure that all connections are made and tight.

General remark

- In normal operation, the burner starts automatically as soon as the boiler temperature drops below the preset temperature.

TOOLS REQUIRED FOR STARTING UP

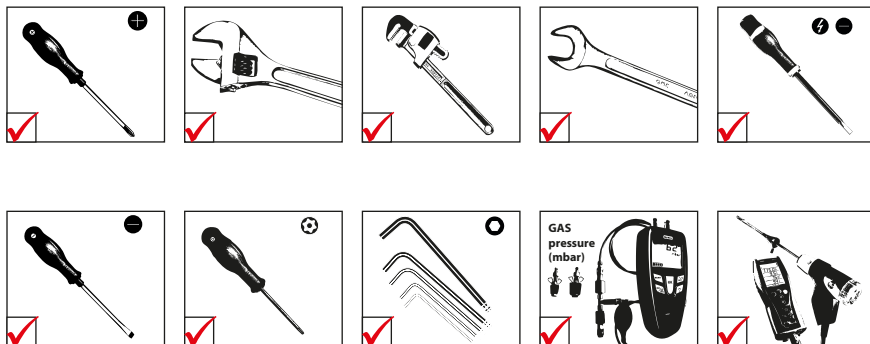

CHECKS BEFORE STARTING UP

Essential recommendation for safety

- Check the tightness of the flue pipe connections.

Essential recommendation for the correct operation of the appliance

- Control the tightness of the hydraulic circuit connections.

FILLING THE SYSTEM

Put the DHW tank under pressure before pressurizing the heating (primary) circuit.

Set-up conditions

- External power supply isolated

DHW circuit filling procedure

1. Open the isolating valves (1) and the draw-off tap (2).
2. Once the water flow rate has stabilized and the air is totally evacuated from the system, close the draw-off tap (2).
3. Check all the connections for leaks.

— Cold water
— Hot water

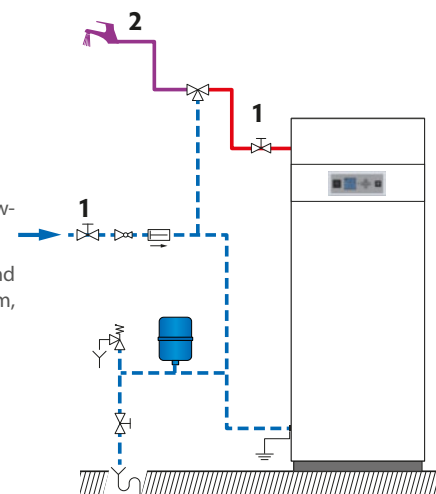

 The drain valve is located underneath and the front cover of the base needs to be removed to get access to it.

Heating circuit filling procedure

1. Open boiler front panel (refer to applicable procedure in the manual).
2. Open the isolating valves (1).
3. Make sure that the drain valve (3) is tightly closed.
4. Open the filling valve (2).
5. Once the system is bled from air, bring the pressure to the static pressure between 1.5 bar and 2 bar.
6. Close the filling valve (2).
7. Disconnect filling device from water supply.*

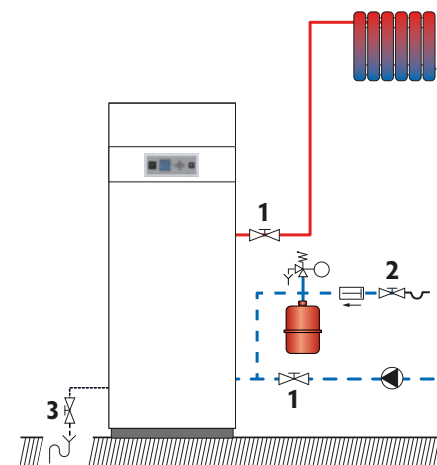

Follow-on tasks

1. Check there is no leak.

* UK specific reference G24.1 & G24.2 of the Water Regulations Guide.

STARTING UP

STARTING UP THE BOILER

Set-up conditions

- All connections made
- Gas conversion carried out as required
- Condensate trap full of water
- Electrical power supply on
- Gas supply open
- Hydraulic circuit(s) full of water

Procedure

1. Check that there is no gas leak.
2. Push in the ON/OFF master switch (⏻).
3. If a room thermostat is installed, possibly increase the temperature set-point to generate a demand.
4. Check the gas pressure and allow the boiler to heat up for a few minutes
5. Check and adjust the burner according to local standards and regulations, refer to “Checking and Adjusting the Burner” on page 47.
6. Set the central heating temperature to the required value using the control panel. Refer to “Boiler Setup Guide” on page 8 and to the Installer’s Handbook.
7. After 5 minutes of operation, bleed the heating circuit until all air is evacuated and restore a 1.5 bar pressure.
8. Bleed the central heating circuit once again and top it up with water to get the required pressure, if necessary.
9. Make sure that the central heating system is properly balanced and, if needed, adjust the valves to prevent certain circuits or radiators from getting a flow rate that is far above or below the set rate.

Follow-on tasks

1. Close the heating circuit filling valve and disconnect the filling connection as required.
2. Check that there are no leaks.
3. Check that the flow rate in the appliance is sufficient as follows :
 - Operate the boiler at maximum power
 - Once the temperatures are stable, read out the supply and return temperatures
 - Check that the difference between the supply and return temperature is equal or less than 20k.
 - If the Delta T is higher than 20k, check the pump settings/specifications.

CHECKING AND ADJUSTING THE BURNER

 When the burner operates at full power, the CO₂ rate must be within the limits mentioned in the technical characteristics, (see “Combustion characteristics” on page 20).

Set-up conditions

- Operating boiler

Procedure

1. Check if the ACVMAX parameters are set to meet the user's requirements (refer to “Boiler Setup Guide” on page 8), and change them if required.
2. Put the boiler to maximum power mode (Refer to the Installer’s Handbook).
3. Using a pressure tester, check that the dynamic gas pressure at the gas valve is at least 18 mbar.
4. Allow the appliance to heat for a few minutes until it reaches at least 60°C.
5. Measure the burner combustion by placing the flue gas analyzer probe in the measurement unit port on the flue pipe and compare the CO and CO₂ values displayed with those indicated in the combustion characteristics table.
6. If the CO₂ value differs by more than 0.3%, carry out the adjustment mentioned in the procedure below.
7. Then put the boiler to the minimum power mode (Refer to the Installer's Handbook provided with the boiler). Allow the boiler to stabilize for a few minutes.
8. Measure the CO₂ level. It must be equal to the value at full power, or lower than that value by 0.5% maximum. If there is a significant deviation, please contact ACV's maintenance department.

CO₂ adjustment procedure

To adjust the CO₂ rate, rotate the throttle screw (1) :

- to the left (counterclockwise) to **increase the CO₂ rate**.
- to the right (clockwise) to **decrease the CO₂ rate**.

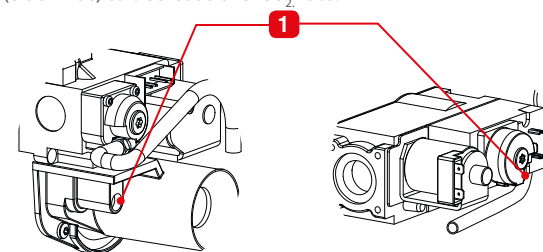

HeatMaster® 25 - 35 - 45 - 70 - 85 TC

HeatMaster® 120 TC



The CO₂ adjustment screw (1) of the HM 120 TC is a worm screw, whose rotation in a direction causes the CO₂ rate to cyclically increase to the maximum, then decrease to the minimum, then increase again, and so on. To adjust, monitor the value change on the analyzer to determine whether the rotation in the selected direction causes the CO₂ value to increase or decrease.

Follow-on tasks

None

RECOMMENDATIONS FOR THE BOILER MAINTENANCE



Essential recommendations for the electrical safety

- Before opening the boiler for maintenance, turn off the boiler by pushing on the ON/OFF master switch.
- Isolate the external power supply of the appliance before performing any operation, unless it is required to take measurements or perform system setup.



Essential recommendations for safety

- Water flowing out of the drain valve may be extremely hot and could cause severe scalding.
- Do not use solvents to clean any of the burner components. The components could be damaged, resulting in unreliable or unsafe operation.
- Check the tightness of the flue pipe connections.



Essential recommendations for the correct operation of the appliance

- It is recommended to have the boiler and the burner serviced at least once a year or every 1,500 hours by a qualified technician, preferably at the start of the heating season. More frequent servicing may be required depending on boiler use. Please consult your installer for advice.
- The boiler and burner maintenance will be carried out by a qualified engineer, and the defective parts may only be replaced by genuine factory parts.
- Make sure to replace any gaskets or seals on the removed components before reinstalling them.
- To ensure maximum efficiency and reliability of the unit, it is recommended that the end-user perform the periodic checks mentioned in the Safety section of this manual.
- Control the tightness of the hydraulic circuit connections.
- Make sure to apply the correct torque value when tightening components. Refer to "Torque Values" on page 51.

TOOLS REQUIRED FOR MAINTENANCE

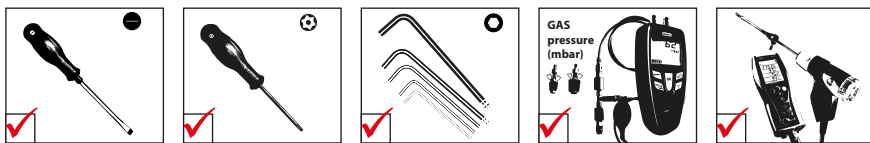
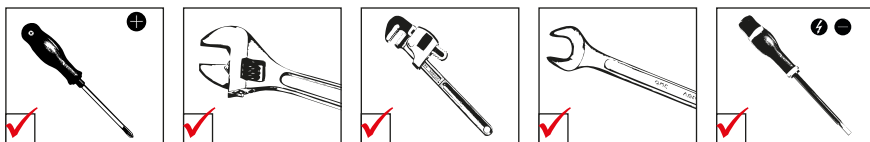

BOILER SHUT DOWN FOR MAINTENANCE

1. Switch the boiler off using the ON/OFF master switch and isolate the external power supply.
2. Close the gas supply valve of the boiler.

PERIODIC BOILER MAINTENANCE TASKS

Tasks	Frequency		
	Periodic inspection	1 year	2 years
	End-user	Professional	
1. Make sure that the system water pressure is at least 1 bar when cold. Top up the system if necessary, adding small quantities of water at a time. In case of repeated fills, call your installer.	X	X	
2. Check that there is no water on the floor under the boiler. Call your installer if there is.	X	X	
3. Check that no error code is displayed on the control panel. Call your installer if necessary.	X	X	
4. Check that all gas, hydraulic and electrical connections are correctly fastened and tight.		X	
5. Check the flue gas exhaust: correct fastening, correct installation, no leaks or clogging.		X	
6. Check that there is no discoloured or cracked area on the burner chamber plate .		X	
7. Check the combustion parameters (CO and CO ₂), see "Checking and Adjusting the Burner" on page 47.		X	
8. Check visually the heating body: no evidence of corrosion, soot deposits or damages. Carry out all required cleaning tasks, repairs and replacements that might be required.		X	
9. Check the electrode, see "Removal, Check and Installation of the Burner Electrode", page 49.			X
10. Remove the burner and clean the exchanger, see "Removal and Installation of the Burner", page 50 and "Cleaning the Exchanger" on page 52.			X
11. Check that the condensate trap is not clogged. If it is, remove it, clean it, and reinstall it i.a.w. "Boiler preparation" on page 39.		X	
12. If a condensate neutralisation system is installed, check it and have it cleaned.	X	X	

DRAINING THE BOILER

! Essential recommendations for safety

- Before draining the DHW tank, drain the heating (primary) circuit or bring its pressure to 0 bar.
- Water flowing out of the drain valve may be extremely hot and could cause severe scalding. Keep people away from the hot water discharge.

Set-up conditions

- Boiler switched off using the ON/OFF master switch
- External power supply isolated
- Fuel/gas supply closed

Heating circuit draining procedure

1. Close the isolating valves (1).
2. Connect the drain valve (2) to the sewer with a hose.
3. Open the drain valve (2) to empty the heating circuit of the boiler.
4. Close the drain valve (2) once the heating circuit of the boiler is empty.

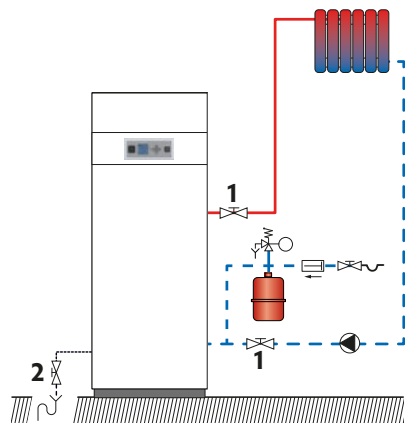

— Cold water
— Hot water



The drain valve is located underneath and the front cover of the base needs to be removed to get access to it.

DHW circuit draining procedure

! Before draining the DHW tank, make sure that the heating (primary) circuit pressure is null.

1. Open fully a draw-off tap (3) for about 60 minutes to make sure that the DHW tank has cooled down.
2. Close the isolating valves (1).
3. Connect the drain valve (2) to the sewer with a hose.
4. Open the drain valve (2) and drain the DHW tank water to the sewer.
5. Open the draw-off tap (3) to accelerate the draining process. If it is located lower than the tank connection, open a draw-off tap located higher in the system.
6. Close the drain valve (2) and the draw-off tap (3) once the DHW tank of the boiler is empty.

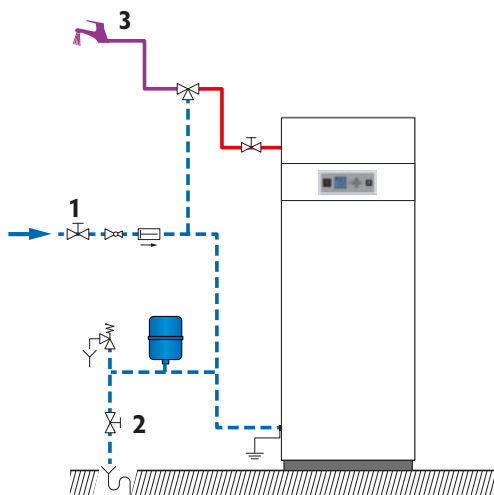

REMOVAL, CHECK AND INSTALLATION OF THE BURNER ELECTRODE

! Essential recommendations for the correct operation of the appliance

- Remove the electrode to control it in case of ignition problems.

Set-up conditions

- Boiler shut down
- External power supply isolated
- Gas supply closed
- Top panel open, refer to "Removal and Installation of the Front and Top Panels" on page 42.

Removal procedure

1. Disconnect the electrode grounding cable from the electrode.
2. Disconnect the electrode ignition cable from the electrical box.
3. Remove two mounting screws (1) and retain them for reinstallation.
4. Remove the electrode (2) and the gasket (3).
5. Check the correct alignment of the electrode ends and that the gap corresponds to the values indicated on the figure below.
6. If the electrode is in bad condition, replace it.

Installation procedure

1. Install a new gasket (3).
2. Install the electrode (2) using the two screws (1), torque i.a.w. "Torque Values" on page 51.

Follow-on tasks

1. Reconnect the grounding cable to the electrode.
2. Reconnect the ignition cable to the electrical box.

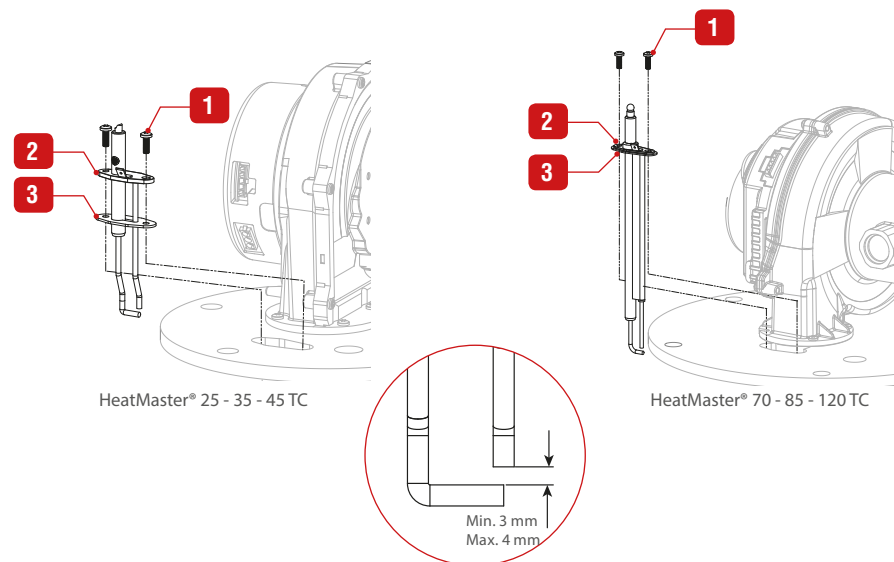

REMOVAL AND INSTALLATION OF THE BURNER

Set-up conditions

- Boiler shut down
- External power supply isolated
- Gas supply closed
- Front and top panels removed (refer to "Removal and Installation of the Front and Top Panels" on page 42).
- Electrode removed or electrode grounding cable and ignition cable disconnected (refer to "Removal, Check and Installation of the Burner Electrode" on page 49).

Removal procedure

1. Disconnect all plugs from the fan assembly (11) and the gas valve (2) and any grounding cable, as required.
2. Disconnect the air inlet elbow (3).
3. Release the gas connection (1).
4. Using a socket wrench, release the burner hood (8) attaching hex. screws and retain them for reinstallation.
5. Lift the burner assembly and pull it out of the exchanger.
6. If required, clean the exchanger, see "Cleaning the Exchanger" on page 52.
7. If not removed previously, remove, check and reinstall the electrode, refer to "Removal, Check and Installation of the Burner Electrode" on page 49.

Installation procedure

1. Reinstall the burner assembly with its insulation block into the exchanger.
2. Install the retaining screws of the burner hood (8) and fasten them in a crosswise pattern at the required tightening torque (refer to "Torque Values" on page 51).
3. Reconnect the gas connection (1).

 **When connecting the air inlet, make sure that the check valve (4) is correctly located at the elbow (3) end.**

4. Reconnect the air inlet elbow (3).
5. Reconnect the plugs to the gas valve (2) and the fan assembly (11), and any disconnected grounding cable.

Follow-on tasks

1. Install the electrode, or reconnect the electrode grounding cable and ignition cable, as required. Refer to "Removal, Check and Installation of the Burner Electrode" on page 49.

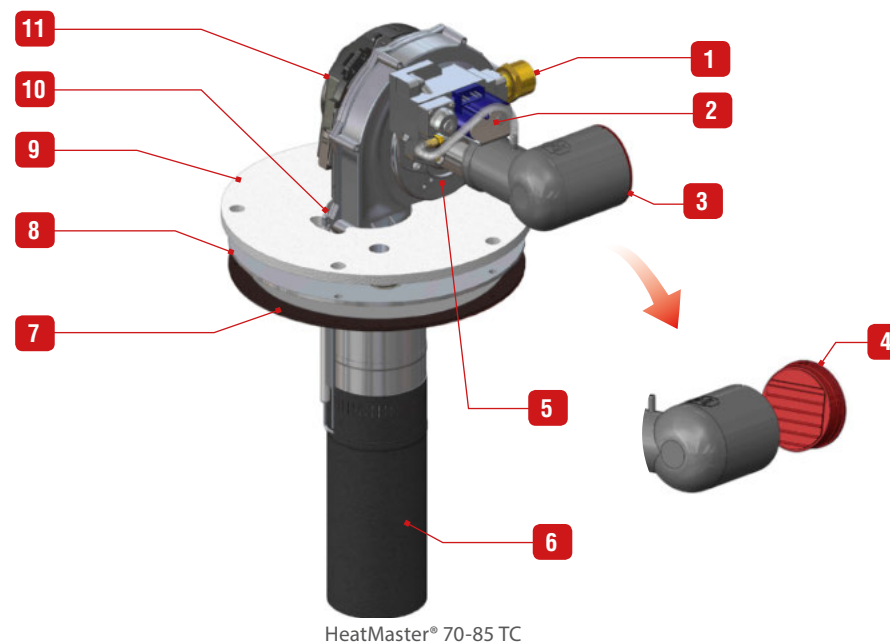
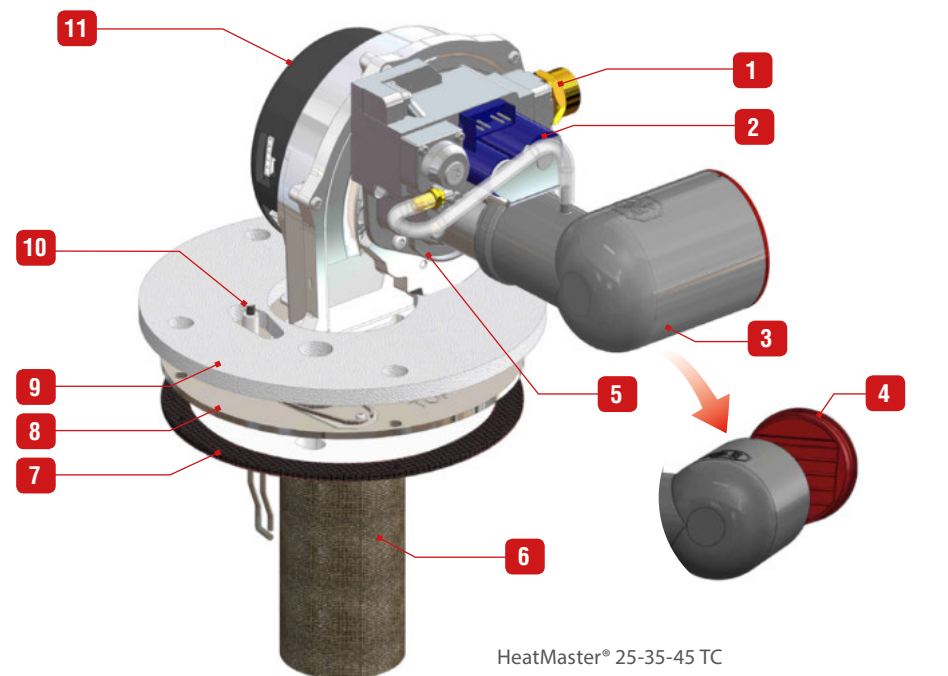

TORQUE VALUES

Description	Tightening torque (Nm)	
	Min.	Max
Burner flange screws	5	6
Electrode screws	3	3.5
Venturi screws (except HM 120 TC)	3.5	4
Gas valve screws (except HM 120 TC)	3.5	4

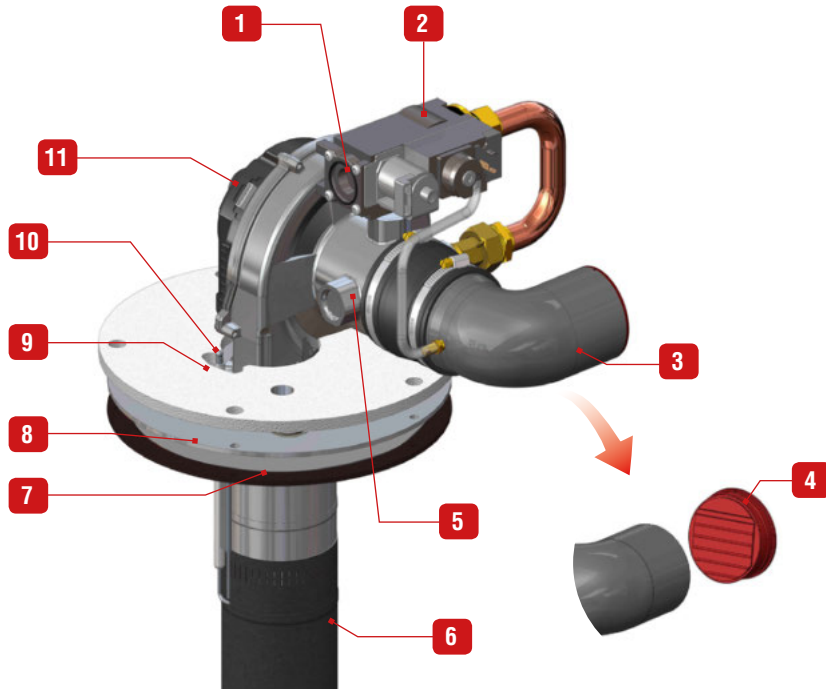

HeatMaster® 120 TC

Detail of the burner components

1.	Gas connection
2.	Gas valve
3.	Air inlet elbow
4.	Air inlet check valve
5.	Venturi
6.	Burner tube
7.	Insulation
8.	Burner hood
9.	Burner hood insulation
10.	Electrode
11.	Fan assembly

CLEANING THE EXCHANGER

Set-up conditions

- Boiler shut down
- External power supply isolated
- Gas supply closed
- Burner removed i.a.w. procedure "Removal and Installation of the Burner" on page 50.
- Front and top panels open, refer to "Removal and Installation of the Front and Top Panels" on page 42.

Procedure

1. Brush and vacuum clean the chamber.
2. Pour some water in the chamber to flush away any foreign deposits that may be present in the heat exchanger.
3. Remove and clean the condensate trap.
4. Reinstall the condensate trap, refer to "Boiler preparation" on page 39.

Follow-on tasks

1. Reinstall the burner according to procedure "Removal and Installation of the Burner" on page 50.
2. Restart the boiler in accordance with procedure "Restarting after Maintenance" on page 52.

RESTARTING AFTER MAINTENANCE

Set-up conditions

- All removed components reinstalled
- All connections made
- Power supply
- Gas supply open
- Hydraulic circuit(s) full of water

Procedure

1. Make sure there is no gas leak at the gas connections.
2. Switch the appliance on using the ON/OFF master switch.
3. Set the appliance at maximum power and check the absence of gas leaks.
4. Check the gas pressure and CO₂ adjustment in accordance with "Checking and Adjusting the Burner" on page 47.

Follow-on tasks

None

Codes	Description of the fault	Solution for the fault
E 01	Failed ignition: The burner failed to light after 5 ignition attempts.	<ol style="list-style-type: none"> 1. Check gas supply to appliance. 2. Check Ignition cable connection in control box. 3. Check electrode for defects, and distance between the pins. 4. Check gas valve and electrical connections to gas valve.
E 02	False flame: Flame detected prior to ignition.	<ol style="list-style-type: none"> 1. Check good electrical ground connection to unit. 2. Check electrode for pollution and deposition of dirt.
E 03	High Boiler temp. : The boiler temperature exceeds 105°C	<p>Correct condition which caused high temperature or limit to open.</p> <ol style="list-style-type: none"> 1. Check water flow in the system (radiator valves). 2. Check Pump and pump electrical connections.
E 05	Blower speed: Blower speed not correct or speed signal is not received by ACVMax.	<ol style="list-style-type: none"> 1. Check blower and wiring harness. 2. Under normal condition if actual fan speed is 1000 rpm different from set fan speed an error is displayed (after 60sec in running and after 30 sec. at startup). 3. Only exception when actual fan speed > 3000 rpm at max. PWM.
E 07	High Flue temp.: Flue temperature exceeds high limit.	<ol style="list-style-type: none"> 1. Heat exchanger may require cleaning. 2. Appliance will automatically reset once flue temperature returns to normal range.
E 08	Flame Circuit Error: Flame circuit test failed	<ol style="list-style-type: none"> 1. Turn appliance off. 2. Check and clean the electrode. 3. Check ignition and grounding cables are firmly connected.
E 09	Gas valve circuit error: Gas valve circuit test failed.	<ol style="list-style-type: none"> 1. Check the gas valve and wiring harness. 2. If the problem persists replace the "ACVMax" circuit board.
E 12	Internal Fault: EEPROM misconfiguration	<ol style="list-style-type: none"> 1. Turn unit off and on to resume normal operation. 2. If the problem persists replace the "ACVMax" circuit board.
E 13	Reset limit reached: Resets are limited to 5 every 15 minutes.	<ol style="list-style-type: none"> 1. Turn unit off and on to resume normal operation. 2. If the problem persists replace the "ACVMax" circuit board.
E 15	Sensor Drift: Supply or return sensor reading has drifted.	Check supply and return temperature sensors and wiring harness.
E 16	Supply Sensor Stuck: Supply sensor reading is not changing.	<ol style="list-style-type: none"> 1. Check supply temperature sensor and wiring harness for shortcuts or other defects. 2. Check waterflow and the temperature balance in the system, because CH supply temperature does not change.
E 17	Return Sensor Stuck: Return sensor reading is not changing.	<ol style="list-style-type: none"> 1. Check return temperature sensor and its position, check wiring harness for shortcuts or other defects. 2. Check waterflow and the temperature balance in the system, because CH return temperature does not change. 3. Failure may happen at low output capacity when supplying from a big tank !
E 18	Sensor Failure: Supply or return sensor reading changed very rapidly.	Check supply and return temperature sensors and wiring harness.
E 19	Flame Failure: Flame failure during start up phase	<p>Flame loss after start up of the appliance.</p> <ol style="list-style-type: none"> 1. Check the flue system for blockage and check the adjustment of the appliance (CO2 high 8.8 +/-0.2%, CO2 low 8.6+/-0.2% measured with front casing open). 2. Also check the Ignition / Ionisation rod (distance to the burner / pollution)
E 21	Internal Control Fault: A / D conversion error.	Turn unit off and on then press OK to resume normal operation.
E 25	Internal Control Fault: CRC check error.	Turn unit off and on to resume normal operation.
E 30	Supply Sensor Shorted: A short circuit has been detected in the appliance supply temperature sensor circuit	<ol style="list-style-type: none"> 1. Check supply temperature sensor and wiring harness for a short circuit. 2. If necessary replace the sensor, or the wire harness. 3. After fixing the problem, reset the appliance and resume normal operation.

Codes	Description of the fault	Solution for the fault
E 31	Supply Sensor Open: An open circuit has been detected in the appliance supply temperature sensor circuit	<ol style="list-style-type: none"> 1. Check supply temperature sensor, connectors and wiring harness for an open circuit. 2. If necessary replace the sensor, or the wire harness. 3. After fixing the problem reset the appliance and resume normal operation.
E 32	DHW Sensor Shorted: A short circuit has been detected in the DHW temperature sensor circuit	<ol style="list-style-type: none"> 1. Check DHW temperature sensor and wiring harness for a short circuit. 2. If necessary replace the sensor, or the wire harness. 3. After fixing the problem reset the appliance and resume normal operation.
E 33	DHW Sensor Open: An open circuit has been detected in the DHW temperature sensor circuit	<ol style="list-style-type: none"> 1. Check DHW temperature sensor, connectors and wiring harness for an open circuit. 2. If necessary replace the sensor, or the wire harness. 3. After fixing the problem reset the appliance and resume normal operation.
E 34	Low Voltage: Line voltage has fallen below an acceptable operating level.	The appliance will automatically reset once line voltage returns to normal.
E 37	Low Water: Water level has fallen below 0.7 bar.	<ol style="list-style-type: none"> 1. Increase pressure to normal range. 2. The appliance will automatically reset once water level returns to normal.
E 43	Return Sensor Shorted: A short circuit has been detected in the appliance return temperature sensor circuit.	<ol style="list-style-type: none"> 1. Check return temperature sensor and wiring harness for a short circuit. 2. If necessary replace the sensor, or the wire harness. 3. After fixing the problem, reset the appliance and resume normal operation.
E 44	Return Sensor Open: An open circuit has been detected in the appliance return temperature sensor circuit.	<ol style="list-style-type: none"> 1. Check return temperature sensor, connectors and wiring harness for an open circuit. 2. If necessary replace the sensor, or the wire harness. 3. After fixing the problem, reset the appliance and resume normal operation.
E 45	Flue Sensor Shorted: A short circuit has been detected in the appliance flue temperature sensor circuit	<ol style="list-style-type: none"> 1. Check flue temperature sensor and wiring harness for a short circuit. 2. If necessary replace the sensor, or the wire harness. 3. After fixing the problem reset the appliance and resume normal operation.
E 46	Flue Sensor Open: An open circuit has been detected in the appliance flue temperature sensor circuit.	<ol style="list-style-type: none"> 1. Check flue temperature sensor, connectors and wiring harness for an open circuit. 2. If necessary replace the sensor, or the wire harness. 3. After fixing the problem reset the appliance and resume normal operation.
E47	Water pressure sensor error: Water pressure sensor is disconnected or broken	<ol style="list-style-type: none"> 1. Check water pressure sensor, connectors and wiring harness. 2. If necessary replace the sensor, or the wire harness. 3. After fixing the problem reset the appliance and resume normal operation.
E 76	Gas pressure switch open	<ol style="list-style-type: none"> 1. Check both the static and the dynamic gas pressures. 2. Correct condition which caused the pressure switch to open 3. Appliance will automatically reset once the pressure switch is closed.
	External Limit Open: An external automatic reset appliance limit has opened.	<ol style="list-style-type: none"> 1. Correct condition which caused limit to open. 2. Appliance will automatically reset once external limit closes
E 77	High temperature mixing circuit	Check if the mixing valve functions correctly.
E 78	Mix circuit sensor shorted	<ol style="list-style-type: none"> 1. Check Mix circuit temp. sensor and wiring harness for a short circuit. 2. If necessary replace the sensor, or the wire harness. 3. After fixing the problem reset the appliance and resume normal operation.
E 79	Mix-circuit sensor Open	<ol style="list-style-type: none"> 1. Check Mix circuit temp. sensor and wiring harness for an open circuit. 2. If necessary replace the sensor, or the wire harness. 3. After fixing the problem reset the appliance and resume normal operation.
E 80	Return > Supply: Return temperature is higher than supply temperature.	Confirm water flows in appliance return and out appliance supply.
E 81	Sensor Drift: Supply and return temperatures are not equal.	<ol style="list-style-type: none"> 1. Check water is flowing through appliance. 2. Wait a few minutes for the water to equalise the temperature, the appliance will automatically reset once temperatures become equal. 3. If appliance doesn't reset, check the NTC's and check the wire harness, replace if necessary.

Codes	Description of the fault	Solution for the fault
E82	Delta T protection blocking - Delta T too high	1. Verify flow in the system. 2. Check pump for blockage and obstructions, unblock it as required. Replace if necessary.
E83	Delta T protection Lock-out - Lock-out due to Delta T value.	1. Verify flow in the system. 2. Check pump for blockage and obstructions, unblock it as required. Replace if necessary.
E 85	Pump operation: warning - Appliance pump is running out of limits.	Pump is running out of its limits. Check pump for blockage and obstructions, replace if necessary
E 86	Pump hard fault: Pump Failure	Pump Failure, check if pump PWM-feedback wire is properly connected, replace pump when necessary
E 87	External Limit Open: An external appliance limit has opened.	1. Correct condition which caused limit to open, then reset appliance. 2. The appliance needs to be reset once external limit closes.
E88	Pump Blocking: Pump attempts to restart.	Check pump for blockage and obstructions, unblock it as required. Replace if necessary.
E 89	Incorrect Setting: A parameter setting is outside the settings range.	1. Review CH & DHW settings and correct as necessary. 2. The appliance will automatically reset once corrected.
E 90	Firmware Mismatch: Control module and display firmware versions are incompatible.	One or several components are not compatible with the system. Replace mismatched component(s).
E 91	System Sensor Shorted: A short circuit has been detected in the system temperature sensor circuit	1. Check system temperature sensor and wiring for a short circuit. 2. If necessary replace the sensor, or the wire harness. 3. After fixing the problem reset the appliance and resume normal operation.
E 92	System Sensor Open: An open circuit has been detected in the system temperature sensor circuit.	1. Check system temperature sensor and wiring for an open circuit. 2. If necessary replace the sensor, or the wire harness. 3. After fixing the problem reset the appliance and resume normal operation.
E 93	Outdoor Sensor Shorted: A short circuit has been detected in the outdoor temperature sensor circuit.	1. Check outdoor temperature sensor and wiring for a short circuit. 2. If necessary replace the sensor, or the wire harness. 3. After fixing the problem reset the appliance and resume normal operation.
E 94	Internal Display Fault: Display memory error	Turn unit off and on to resume normal operation.
E 95	Supply Sensor Error: Supply sensor reading is invalid	1. Check wiring between display and control module. 2. If necessary replace the sensor, or the wire harness. 3. After fixing the problem reset the appliance and resume normal operation.
E 96	Outdoor Sensor Open: An open circuit has been detected in the outdoor temperature sensor circuit.	1. Check outdoor temperature sensor and wiring for an open circuit. 2. If necessary replace the sensor, or the wire harness. 3. After fixing the problem reset the appliance and resume normal operation.
E 97	Cascade Mismatch: Cascade configuration has changed.	1. Run autodetection if change was intentional, or else check wiring between appliances. 2. Appliance will automatically reset once repaired.
E 98	Cascade Bus Error: Communication with other appliances has been lost.	1. Check wiring between appliances. 2. Appliance will automatically reset once repaired.
E 99	Controller Bus Error: Communication between appliance display and control module has been lost.	1. Check wiring between components. 2. Appliance will automatically reset once repaired.



DECLARATION OF CONFORMITY TO STANDARDS

1/1

Product type: **Condensing boiler**Name and address of manufacturer: **ACV International SA / NV
Oude Vijverweg, 6
B-1653 Dworp
Belgium**

This declaration of conformity is issued under the sole responsibility of the manufacturer.

Model: **HeatMaster 25 C V15
HeatMaster 25 TC V15
HeatMaster 35 TC V15
HeatMaster 45 TC V15
HeatMaster 70 TC V15
HeatMaster 85 TC V15
HeatMaster 120 TC V15**

We declare hereby that the appliance specified above is conform to the following regulations and directives:

Regulation/ Directive	Description	Date
(EU) 2016/426	Regulation relating to appliances burning gaseous fuels	09.03.2016
2009/125/EC	Ecodesign Directive (implemented by EU regulation 813/2013)	21.10.2009
2014/35/EU	Low Voltage Directive	26.02.2014
2014/30/EU	Electromagnetic Compatibility Directive	26.02.2014

Relevant harmonised standards :

EN 15502-1	EN 677	EN 61000-3-2
EN 15502-2	EN 55014-1	EN 61000-3-3
EN 60335-2-102	EN 55014-2	

The notified body, (KIWA Nederlands B.V., Wilmersdorf 50, PO Box 137, 7300 AC APELDOORN, The Netherlands [0063]) performed a Type Examination and issued the certificate(s) Nb 17GR0164/00, ID # **0063CQ3618**Signed for and on behalf of
ACV International SA/NV

Dworp, 09/08/2018

R&D Director
Sara Stas

ADDITIONAL ECODESIGN DATA

Boiler type and model	HeatMaster TC		25	35	45	70	85	120
Condensing boiler			<input checked="" type="checkbox"/>	<input checked="" type="checkbox"/>	<input checked="" type="checkbox"/>	<input checked="" type="checkbox"/>	<input checked="" type="checkbox"/>	<input checked="" type="checkbox"/>
Low temp boiler			<input checked="" type="checkbox"/>	<input checked="" type="checkbox"/>	<input checked="" type="checkbox"/>	<input checked="" type="checkbox"/>	<input checked="" type="checkbox"/>	<input checked="" type="checkbox"/>
Combination heater			<input checked="" type="checkbox"/>	<input checked="" type="checkbox"/>	<input checked="" type="checkbox"/>	<input checked="" type="checkbox"/>	<input checked="" type="checkbox"/>	<input checked="" type="checkbox"/>
Useful heat output								
at 30% of rated heat output	P_1	kW	7.95	11.2	14.6	22.2	26.7	36.16
at rated output and high-temp regime	P_4	kW	24.3	34.2	44.7	68	82.5	111.6
Useful efficiency								
at 30% of rated heat output	η_1	%	98.2	98.6	98.2	98.2	97.3	97.3
at rated output and high-temp regime	η_4	%	87.6	88.2	88.2	87.6	87.4	87.4
Auxiliary electricity consumption								
At full load	e_{lmax}	W	95	110	126	210	266	327
At part load	e_{lmin}	W	19	30	40	50	46	70
In standby mode	P_{sB}	W	3	3	3	3	3	3
Standby heat loss	P_{stby}	W	92	95	113	167	167	167



Product Fiche: HeatMaster C & TC
Referring to Commission Delegated Regulation N° 811/2013

Model	HeatMaster 25 C	HeatMaster 25 TC	HeatMaster 35 TC	HeatMaster 45 TC	HeatMaster 70 TC	HeatMaster 85 TC	HeatMaster 120 TC
Medium temperature application	condensation	condensation	condensation	condensation	condensation	condensation	condensation
declared load profile for water heating	XXL	XXL	XXL	XXL	XXL	XXL	XXL
Seasonal space heating energy efficiency class	A	A	A	A	A	A	A
Water heating efficiency class	B	A	A	A	A	A	A
Rated heat output (kW)	24	24	34	45	68	83	112
Annual energy consumption for space heating (kWh)	12031	12170	17154	22496	38253	45233	56518
Annual energy consumption for water heating (kWh)	8151	6028	6028	6028	6288	6288	6288
Seasonal space heating efficiency %	93	93	93	93	93	92	92
Water heating efficiency (%)	74	87	87	87	85	85	85
Sound power level indoors LWA:	60	60	60	59	60	61	62
Able to work only during off-peak hours:	No	No	No	No	No	No	No

ACV International Oude Vijverweg, 6 1653 Dworp (Belgium)
13/09/2018
A1002289 – Rev B